

AlgoLaser **ALSEC 2.0**

# QUICK START GUIDE

Smart Enclosure 2.0 for Laser Engraving

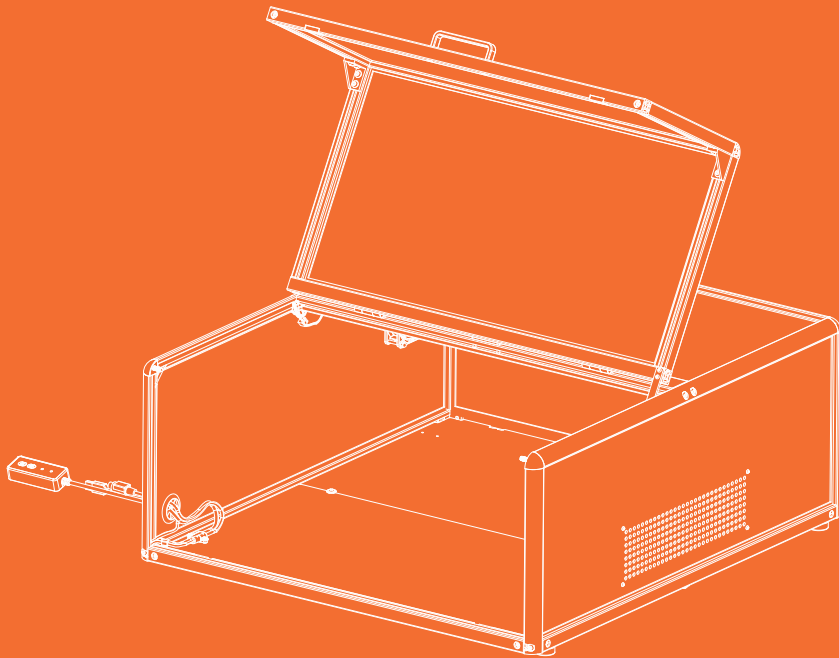

Please read this manual before use and keep it properly for future reference.



# ENGRAVING HAPPINESS

## Thanks for choosing AlgoLaser!

We are so glad that you give it a home.

We have packed everything into the neatest form, utilizing laser engraving machines, to help you enjoy engraving, achieve the greatest yield, and realize your dream.



The Founder of AlgoLaser

### Aftersale Policy

- **12-Months Limited Warranty**

We provide 12 months warranty for every product from the date of purchase against defects in materials and workmanship. And we will offer repair or replacement service according to the product condition. Please note that this warranty does not cover damaged product caused by misuse or abuse.

- **Return or Exchange Policy**

For detailed policy, please refer to the return and exchange policy on the platform you purchased from.

- **Misdelivery & Missing Parts**

If you receive an incorrect product or discover missing parts after receiving the product, please contact our customer service. AlgoLaser will cover the shipping cost of the incorrect product or send the replacement parts.

- **Troubleshooting Support**

AlgoLaser offers online troubleshooting guides that helps you to solve problems step-by-step. Please reach [algolaser.com](http://algolaser.com) to get tutorial videos, FAQs, and tech support from professional engineers.

### Aftersale Support

1 Please go to <http://algolaser.com/support/> to submit your inquiry. To help engineer make faster judgment and provide effective solutions, please provide related pictures and videos within the inquiry.

2 Information needed:

Machine Model

Laser Module

Purchase Channel

Delivery Date

Computer System

Software

Problem Description, Video & Photo

3 After submitting, our engineer will reply you within 24 hours.

# CONTENTS

---

## 01 Before You Start

1.1 Item List -----	1
---------------------	---

02 Enclosure Assembly -----	6
-----------------------------	---

## 03 How to Use

3.1 Compatible Devices -----	27
3.2 How to Use ALSEC 2.0 -----	28
3.3 Use LightBurn to Operate -----	32
3.4 Use LightBurn to Control Camera -----	35
3.5 Use LaserGRBL to Operate -----	40

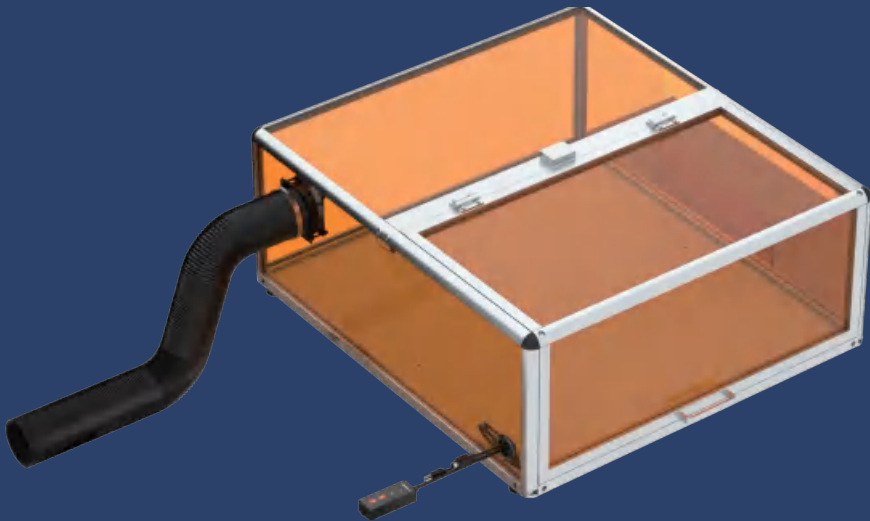

# 01

## Before You Start

---

# 1.1 Item List

Note: Please refer to the label attached to the real object to install.  
The side with the label (A,B,C,D,E,F,G,H) is the outer surface of the box.



Left panel



Right panel



Top panel



Rear panel



Top cover panel

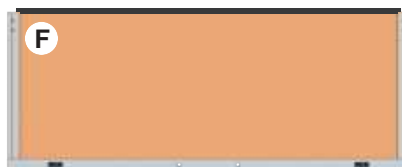

Front cover panel

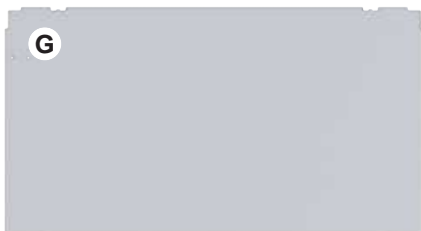

Bottom plates

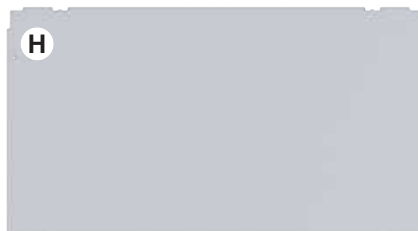

Bottom plates



Upper rear frame



Lower rear frame



Front frame



Support frame

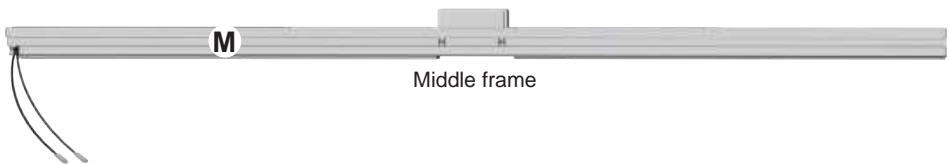

Middle frame



Handle



Angle brackets



Hook

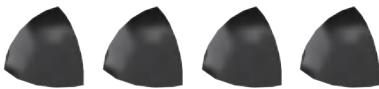

Three-dimensional connector cover



Hinge



Clamp



Smoke pipe



Exhaust fan



Flange interface



Fan mesh

---



M4\*35 screw



M4 nut



M4\*16 screw



M4\*10 screw



M3\*8 screw



M3\*10 screw



M5\*16 screw



M6\*20 screw



M6\*16 screw



M6\*12 screw



M5\*12 screw

---



2mm / 2.5mm / 3mm / 4.0mm allen key



Wrench

---

\* The above images are for reference only. Please refer to the actual product.



# 02

## Enclosure Assembly

---



Assembling Enclosure may bring some challenges,  
Don't worry, follow the steps step by step to complete it!



01 / 14

## Assemble the exhaust fan

Use an open-end wrench to lock the fan with 4 M4\*35 screws and M4 nuts.



Exhaust fan



Flange interface



Fan mesh



M4\*35 screw \*4



M4 nut \*4

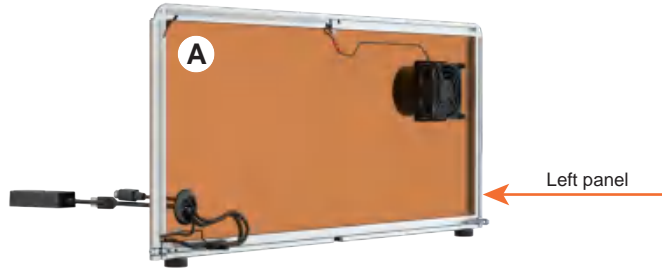

Note the direction of the exhaust fan

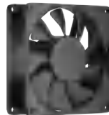

This side faces the inside of the box.



This side faces the outside of the box.

1

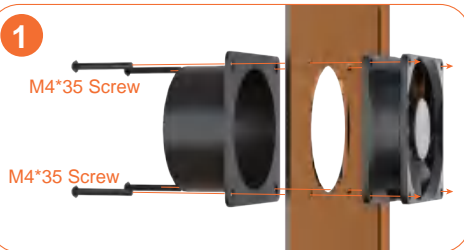

2

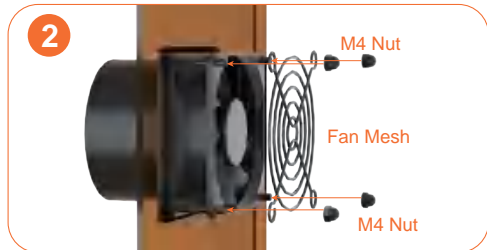

3

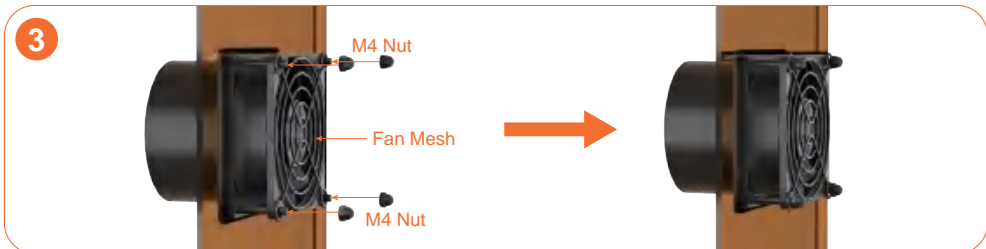

Please refer to the installation video in the Smart Enclosure 2.0 playlist on <https://www.youtube.com/@algolaserofficial/playlists>.

 **02** / 14

**Assemble the rear panel and lower rear frame**

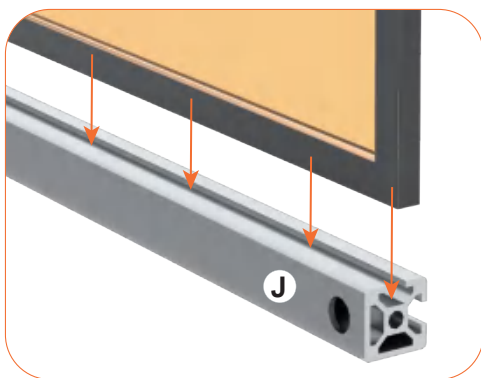
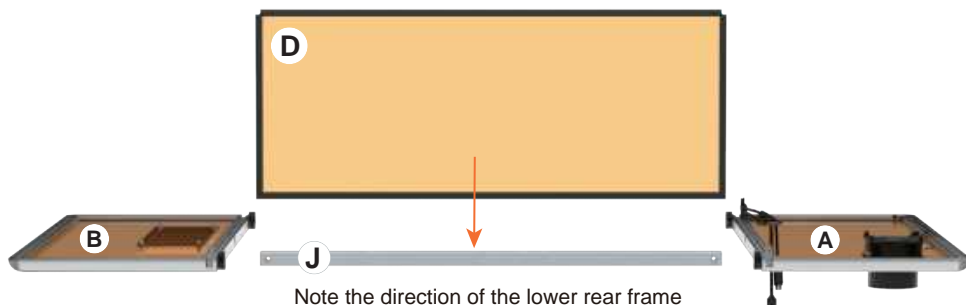
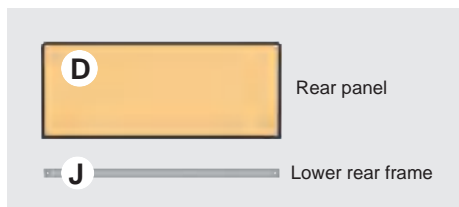

Connect the rear panel with the lower rear frame

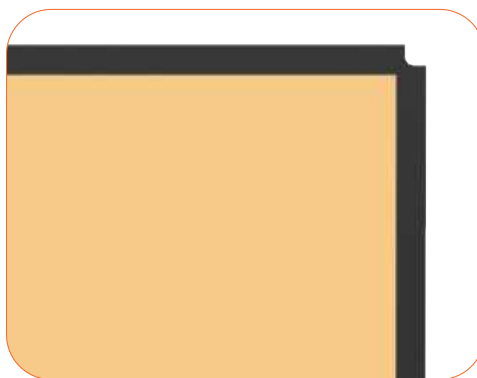

Note that the corner side of the rear panel facing up, and the other side facing down

# 03/14

## Assemble the left and right panel

Connect the left and right panel with the lower rear frame, then lock in two M5\*12 screw \*2.

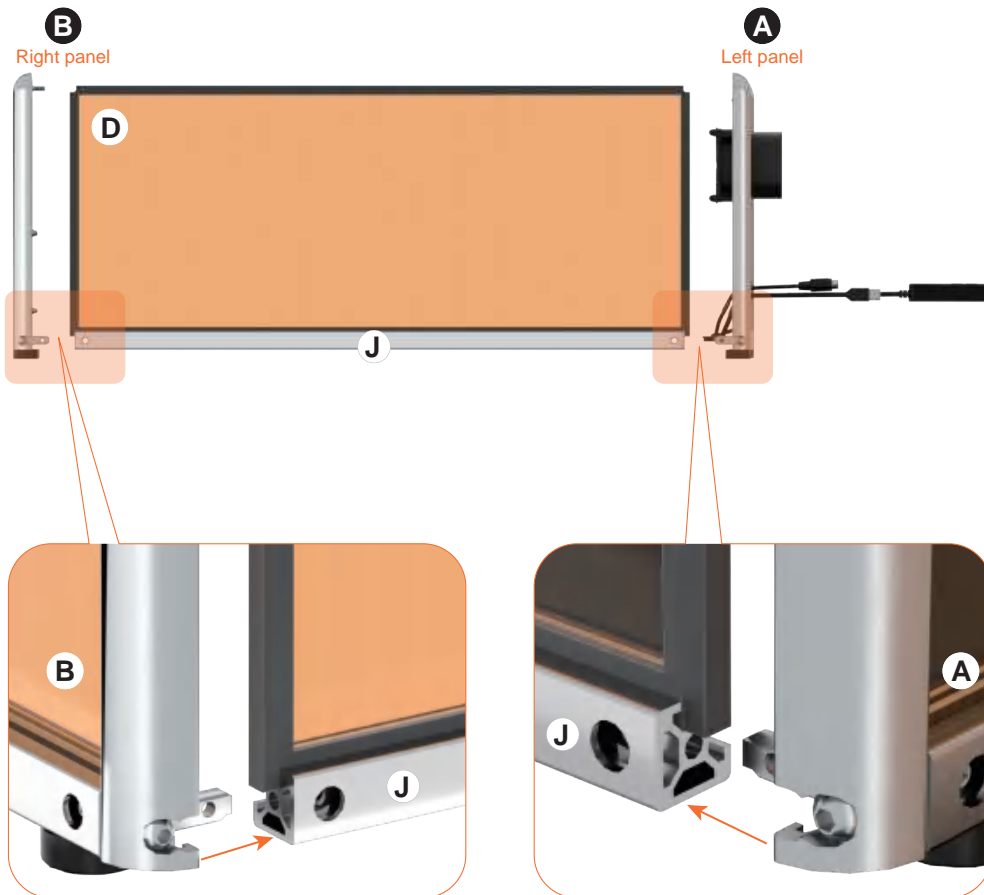

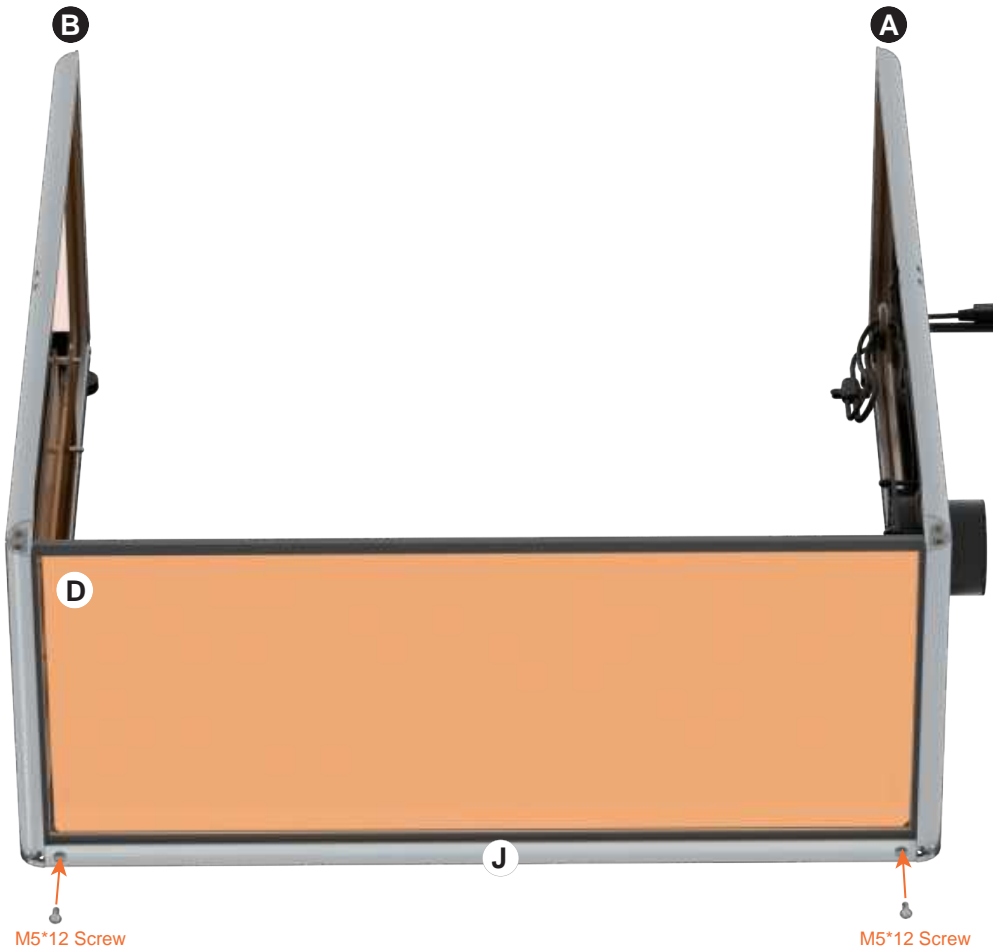

# 04 / 14

## Assemble the upper rear frame

Put the upper rear frame on the rear panel.  
Lock a M6\*16 screw in each side of the frame.

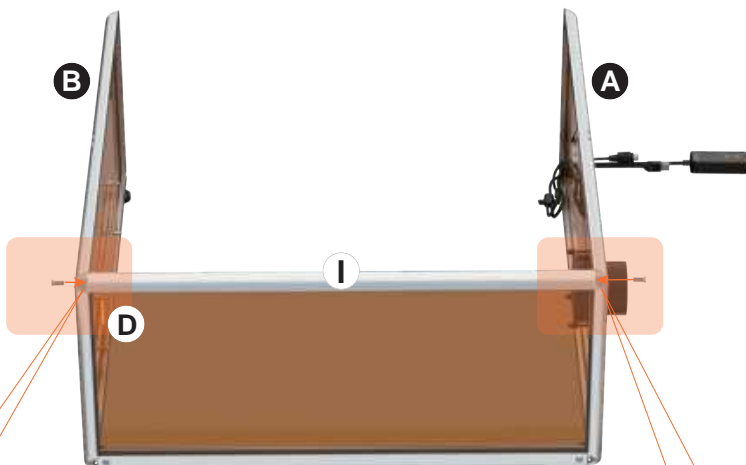
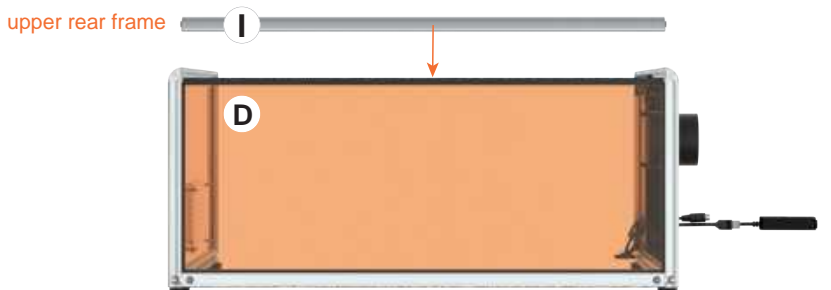

# 05/14

## Assemble the support frame

Use two M5\*16 screws to connect the support frame with the panels installed.

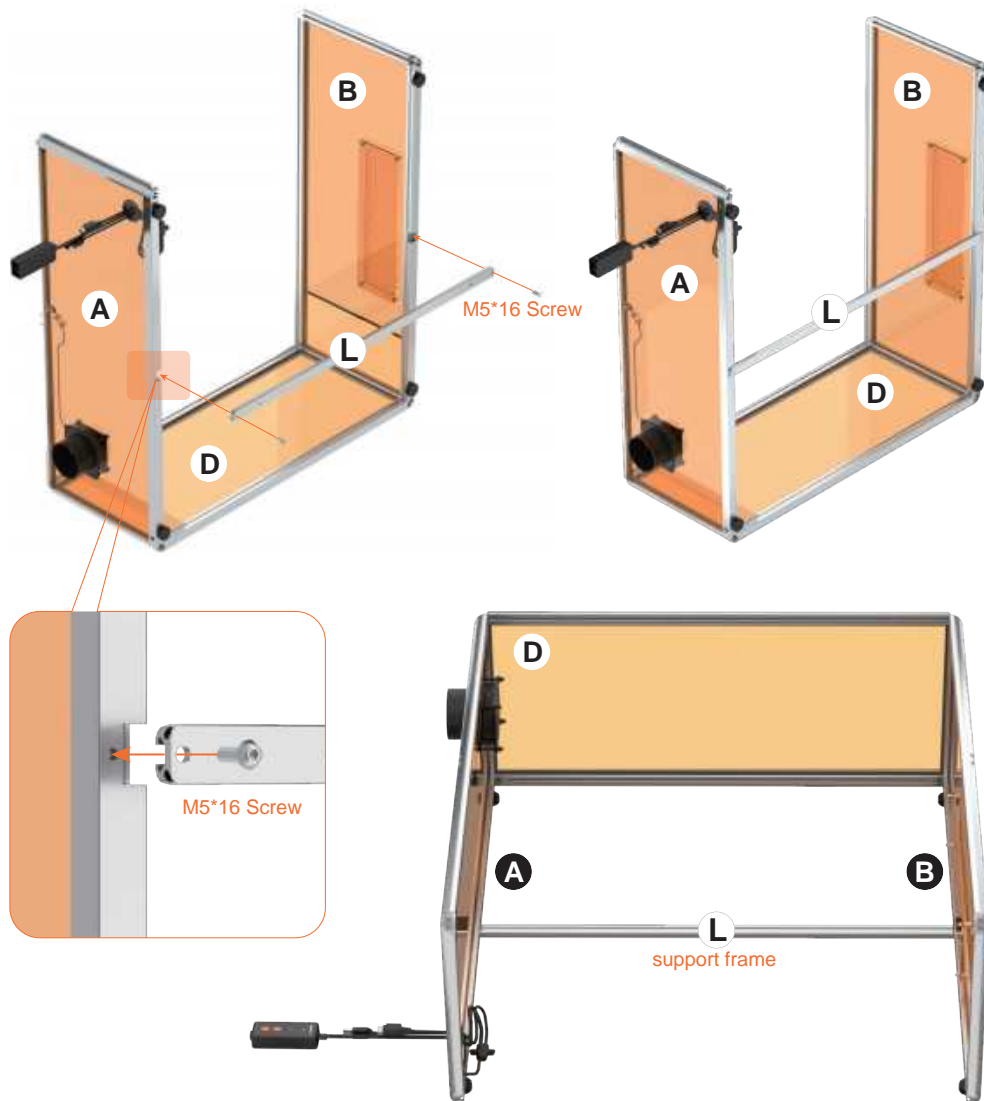





06 / 14

## Assemble the bottom plates

Insert the bottom plates,  
Fix the bottom plate with M6\*12 screws in the middle.



Bottom plates



M6\*12 Screw \*2

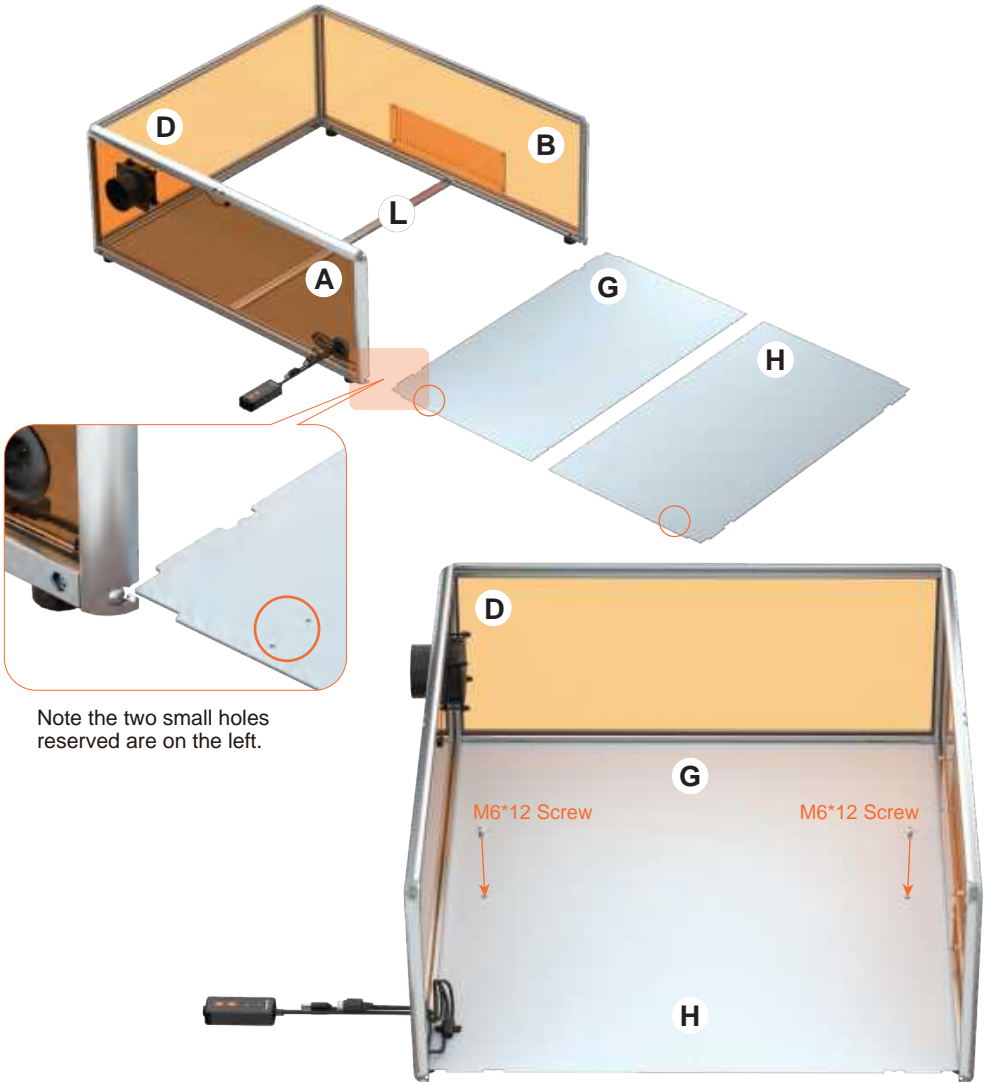

Note the two small holes reserved are on the left.

 **07** / 14

**Assemble the lower front frame**

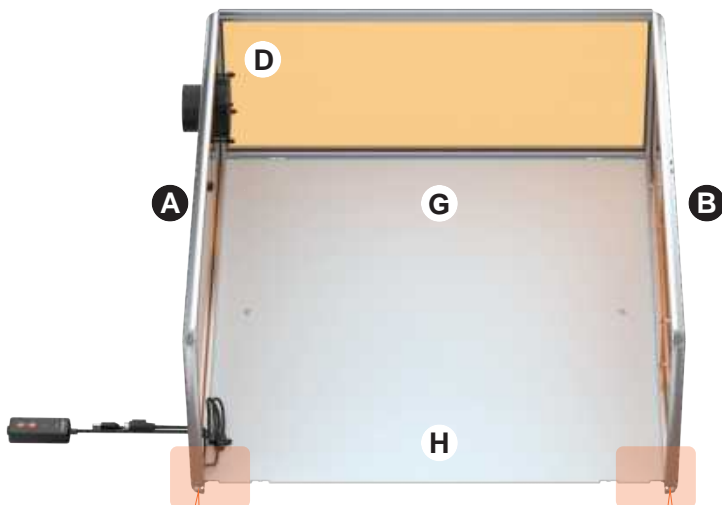
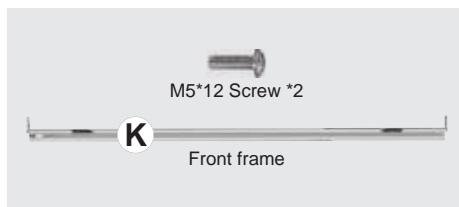

Notice: To install the lower front frame easily, loosen two pre-installed M6 screws.

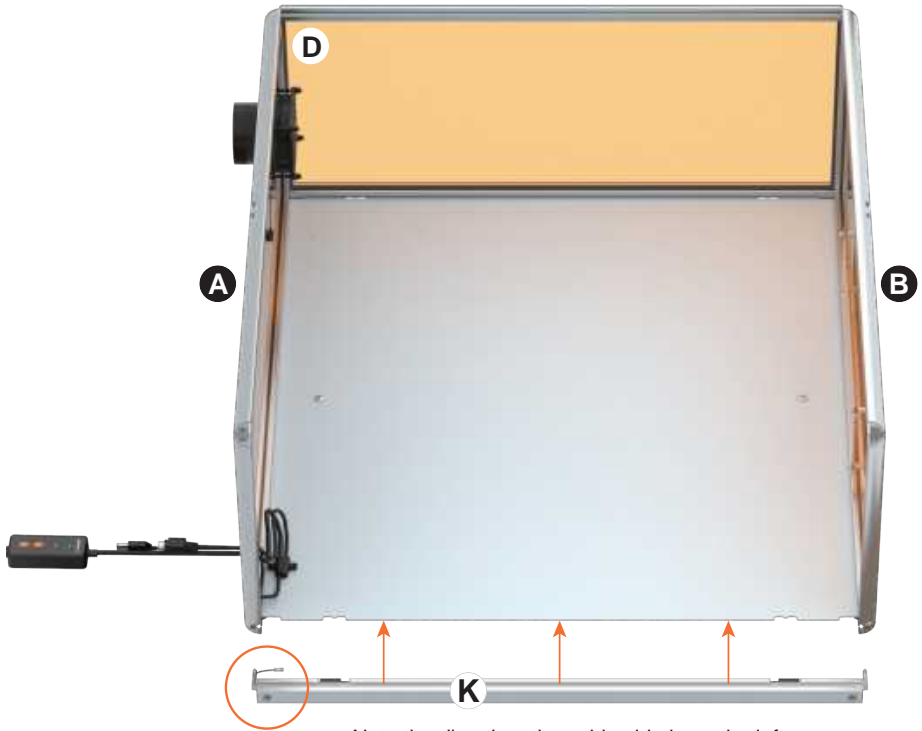

Note the direction, the cable side is on the left.

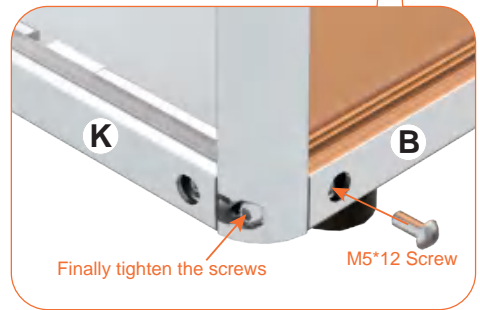
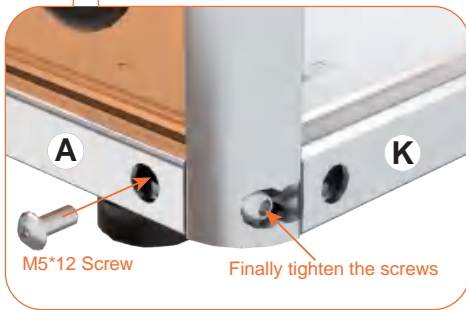
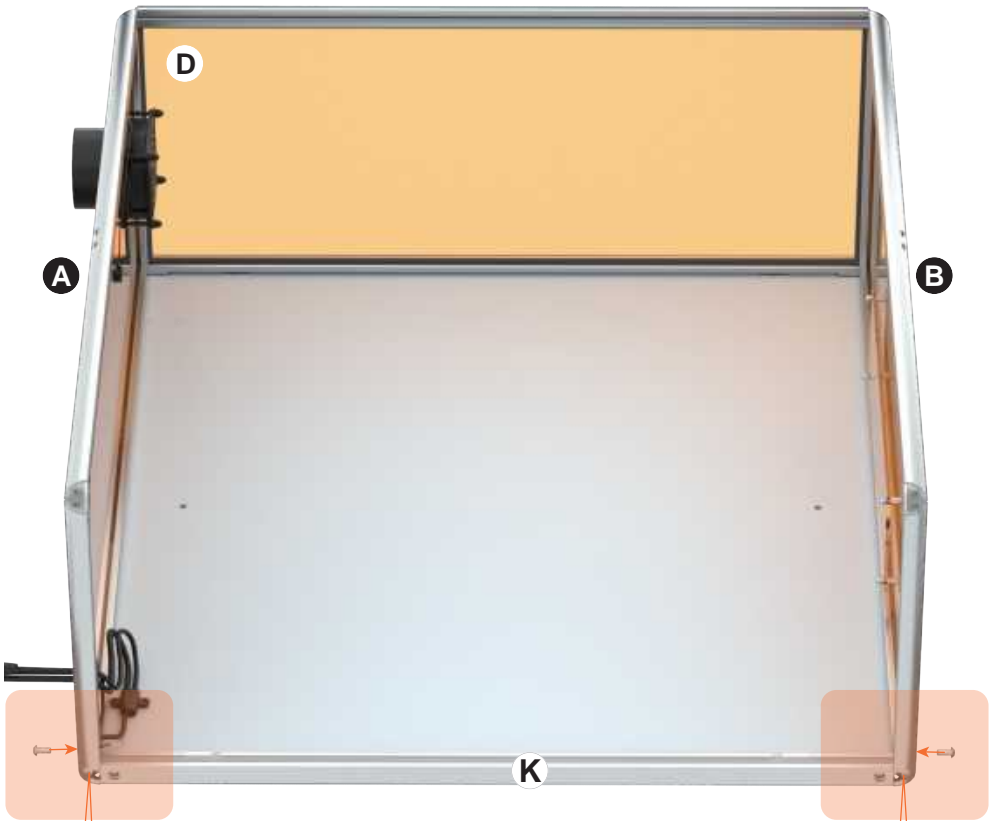

 **08** / 14

## Assemble the top panel



Install one side then the other.

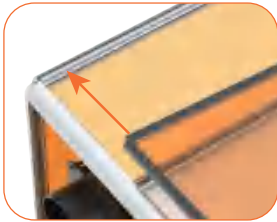

Note the direction,  
the corner side faces the rear panel.

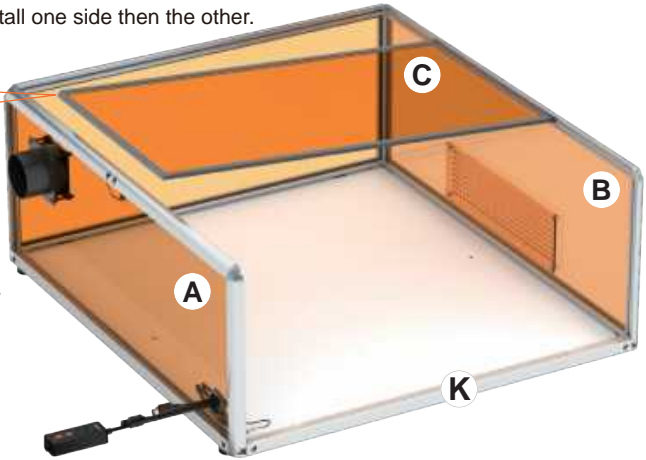

Push the top panel forward into the upper rear frame and tighten it.

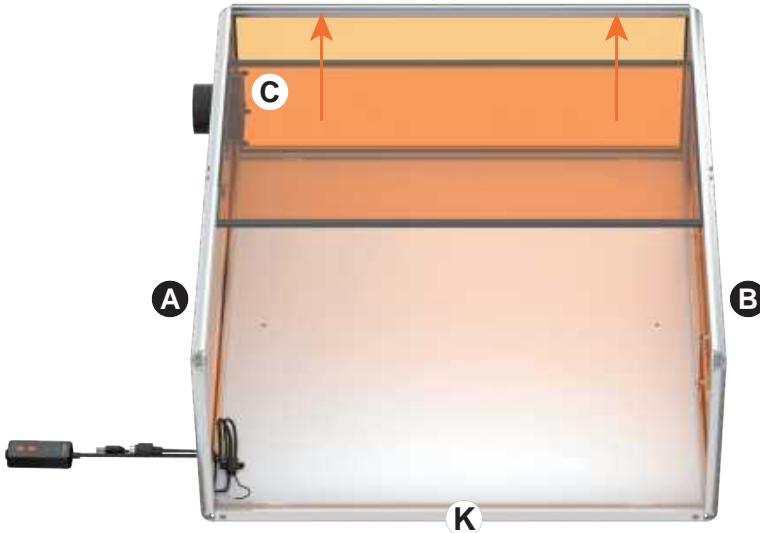

## 09/14

### Assemble the middle frame

Connect the middle frame with the top panel.  
Use four M6\*20 screws to fasten the two parts.

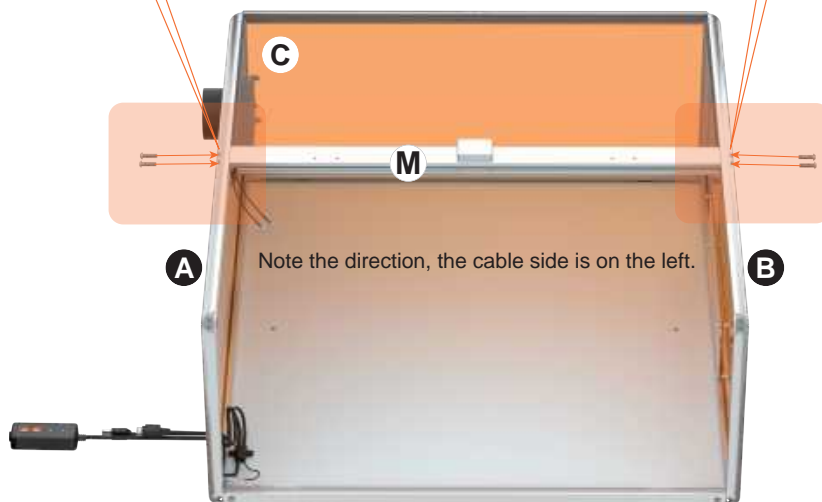
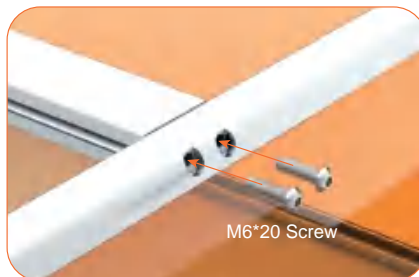
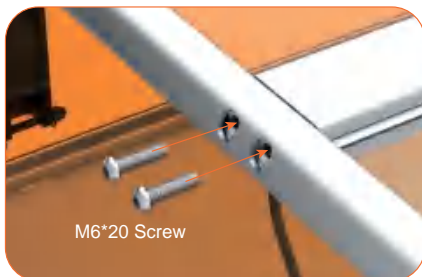
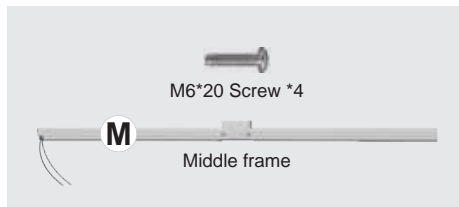

# 10/14

## Assemble the top and front cover panel

Connect the top and front cover panel with the angle brackets and tighten them with M6\*20 screws.

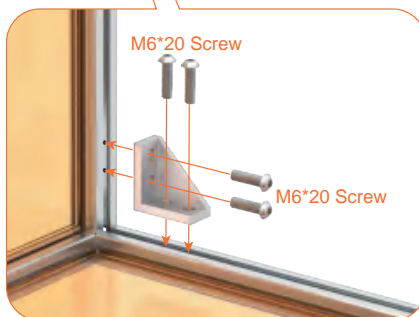
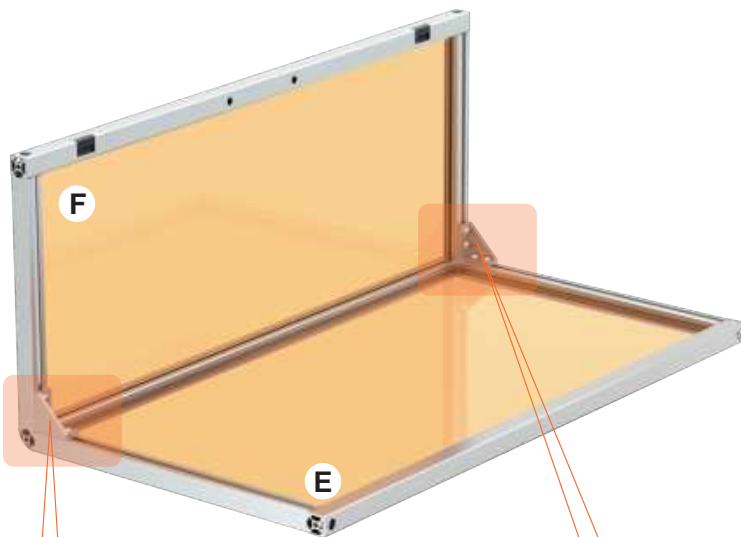

80% completed, keep up the good work! We will be able to see the complete Smart Enclosure 2.0 soon!

# 11 / 14

## Assemble the handle, hook, and hinge

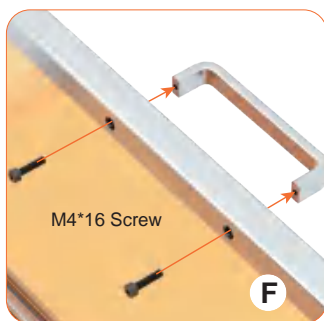
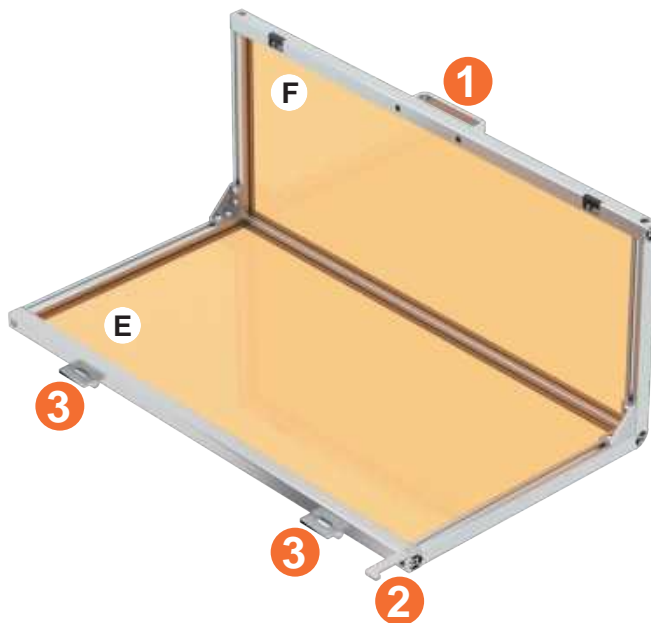
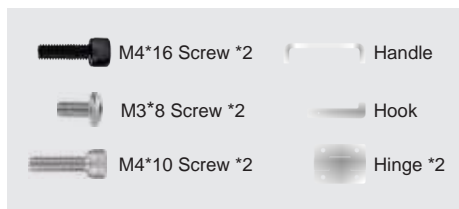

1

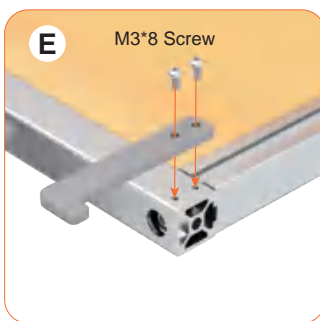

2

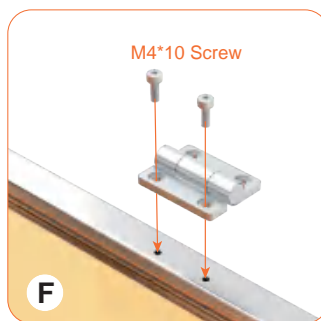

3



## 12/14

### Connect the lid to the main body

Use M4\*10 screws to lock the hinge to connect the lid and the main body.

 M4\*10 Screw \*2

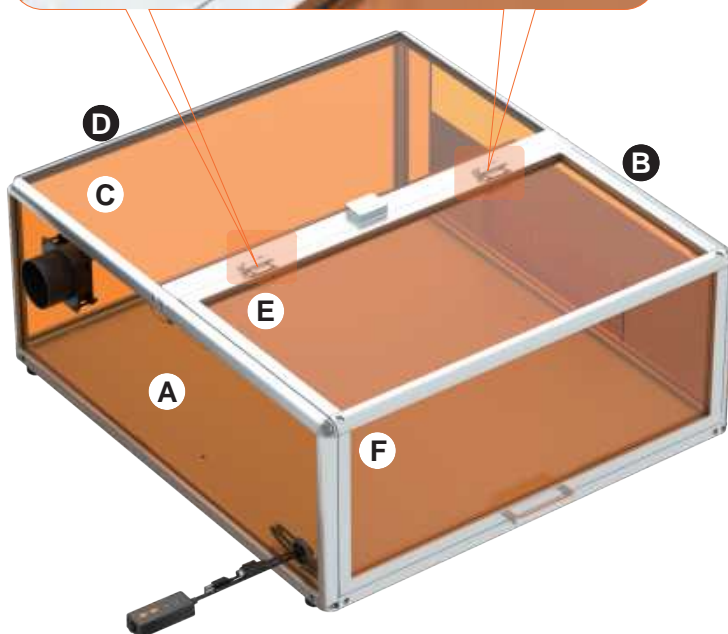



13/14

## Assemble the three-dimensional connector cover, clamp, smoke pipe



Three-dimensional connector cover \*4



Clamp



Smoke pipe

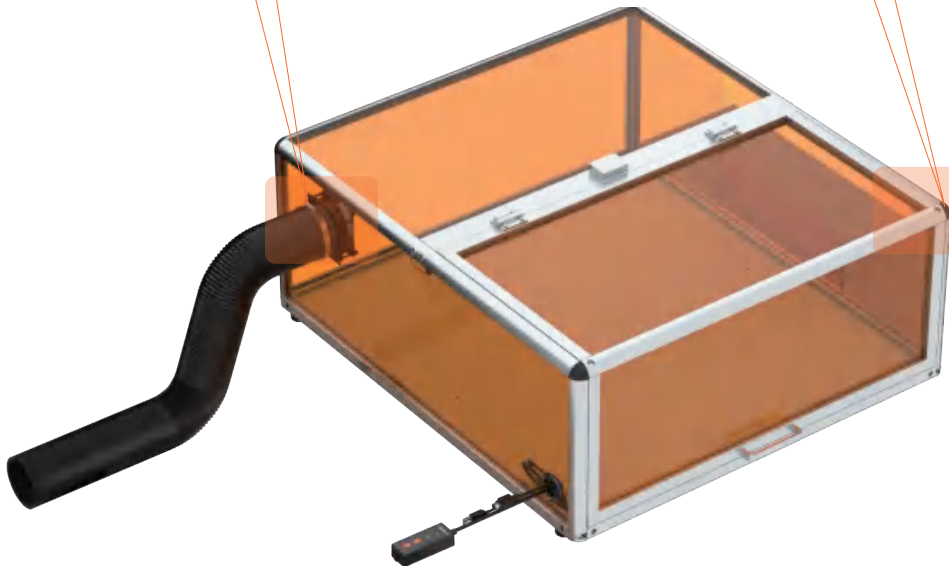
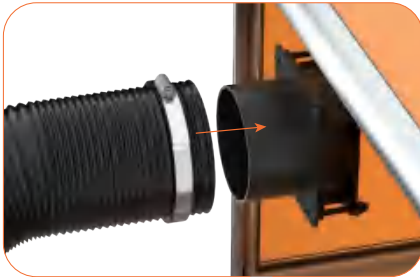

Insert the smoke pipe into the clamp, then into the exhaust flange, and use the open-end wrench to tighten the screws on the clamp.

# 14/14

## Cable management and connection

The cable is pre-installed. Please lock in two screws and connect four accessories.



M3\*10 Screw \*2

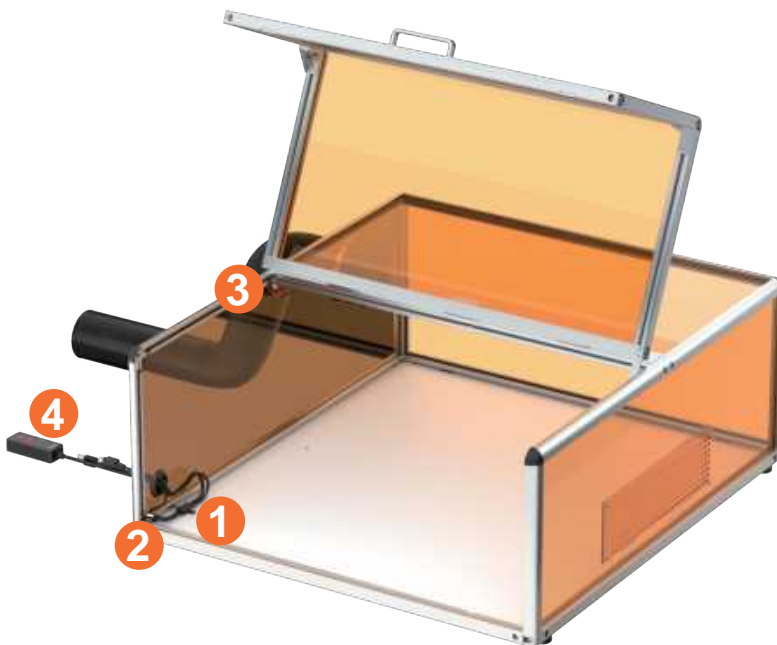

Use two M3\*10 screws to lock the wire splitter into the bottom plate  
(The cables are threaded, please lock.)



**Limit switch air docking interface**

This is the door sensor air docking interface: the interface and docking terminal are 2PIN white interfaces. The cable connected the interface and the wire splitter is hidden in the lower front frame. (The diagram above is the wire splitter.)

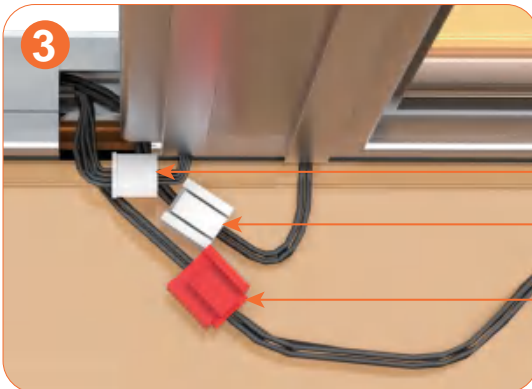

**Camera interface:**  
white PH2.0 4PIN air docking interface

**Light interface:**  
white HY2.0 2PIN air docking interface

**Fan interface:**  
red HY2.0 3PIN air docking interface

**Controller:**  
To turn on/off the lights and fan.

**USB connector:**  
Connect the camera  
to the computer.

**DIN 4PIN:**  
Power connector,  
connect to the machine  
or smart hub.









Great, the assembly is done!

# 03

## How to Use

---

### 3.1 Compatible Devices

Machine Type	Lid Lifted	Lid Closed
DIY KIT MK2	 A photograph of the DIY KIT MK2 laser cutter with its lid open. The machine is housed in a silver metal case with an orange interior. A black flexible extraction duct is connected to the side of the machine.	 A photograph of the DIY KIT MK2 laser cutter with its lid closed. The machine is housed in a silver metal case with an orange interior. A black flexible extraction duct is connected to the side of the machine.
Alpha MK2	 A photograph of the Alpha MK2 laser cutter with its lid open. The machine is housed in a silver metal case with an orange interior. A black flexible extraction duct is connected to the side of the machine.	 A photograph of the Alpha MK2 laser cutter with its lid closed. The machine is housed in a silver metal case with an orange interior. A black flexible extraction duct is connected to the side of the machine.
DIY KIT MINI	 A photograph of the DIY KIT MINI laser cutter with its lid open. The machine is housed in a silver metal case with an orange interior. A black flexible extraction duct is connected to the side of the machine.	 A photograph of the DIY KIT MINI laser cutter with its lid closed. The machine is housed in a silver metal case with an orange interior. A black flexible extraction duct is connected to the side of the machine.



## 3.2 How to Use ALSEC 2.0

- Put the machine into the enclosure.



- The indicator shows red when the lid is lifted.



- The indicator shows green when the lid is closed.



- Push the light button to turn on/off the light inside, and the light icon on the screen shows ON/OFF

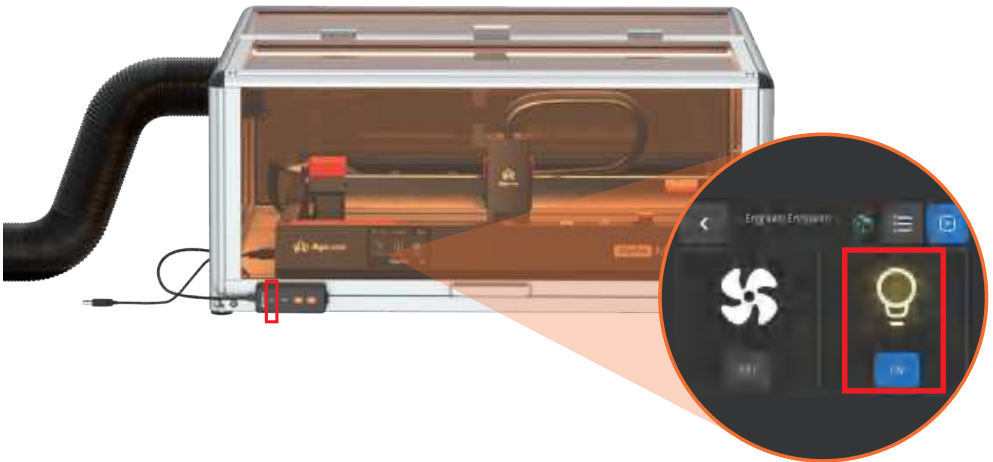

- Push the fan button to turn on/off the fan, and the fan icon on the screen shows ON/OFF

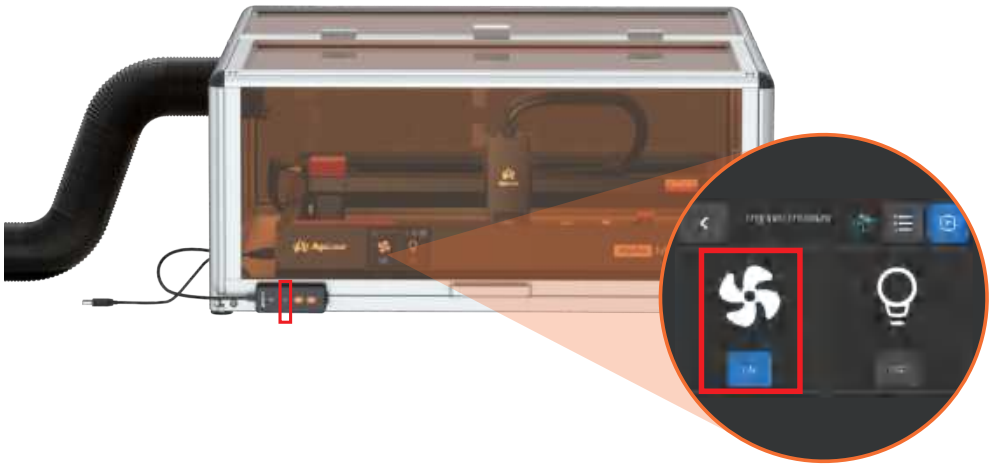

- Engraving will be paused when the safety lid lifts.



- Engraving continues after closing the safety lid.

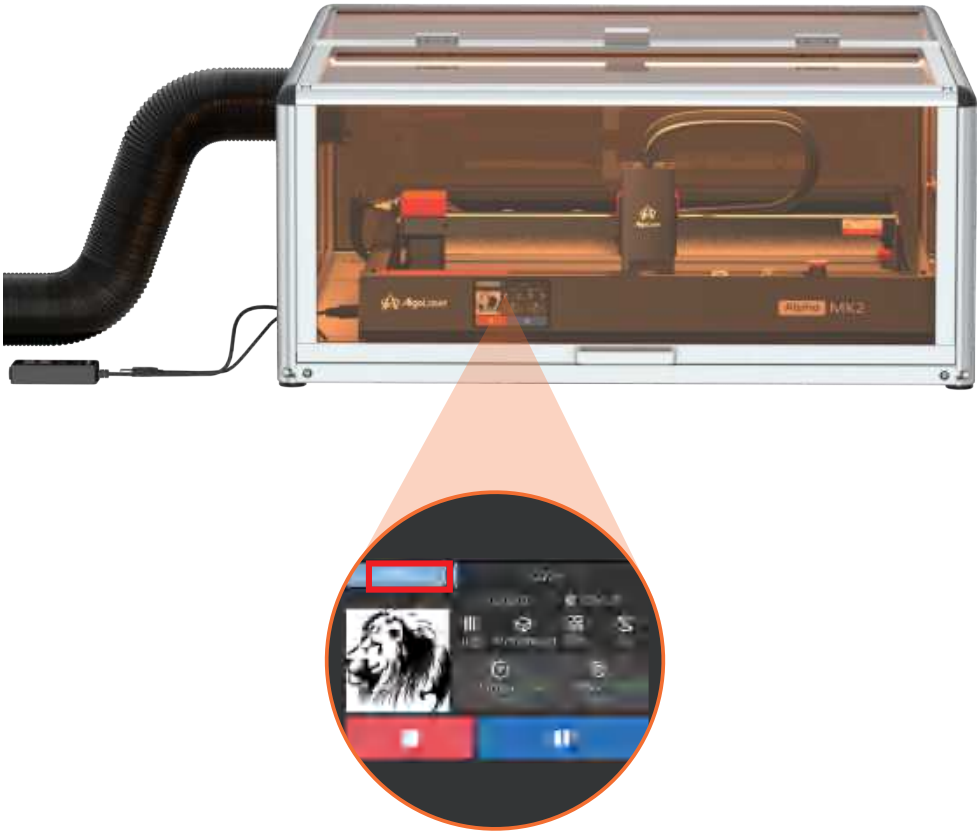

LaserGRBL / LightBurn software.

LightburnSoftware.com



lasergrbl.com



Note: The LightBurn software requires a purchase to use.

### 3.3 Use LightBurn to Operate

- Connect Alec 2.0 with LightBurn. The “ok” on the console field means connection is successful.

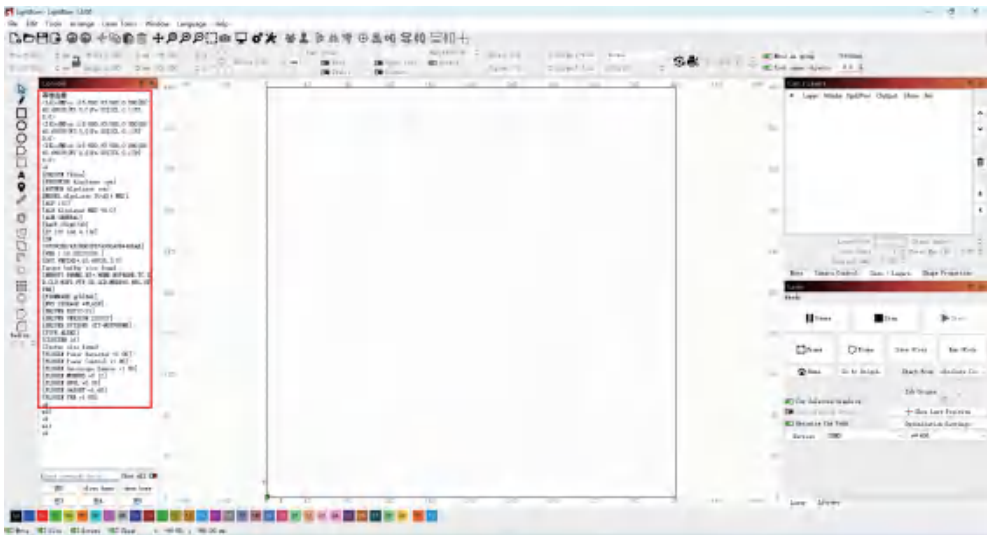

- Send "M12" to the console field to turn on the lights.

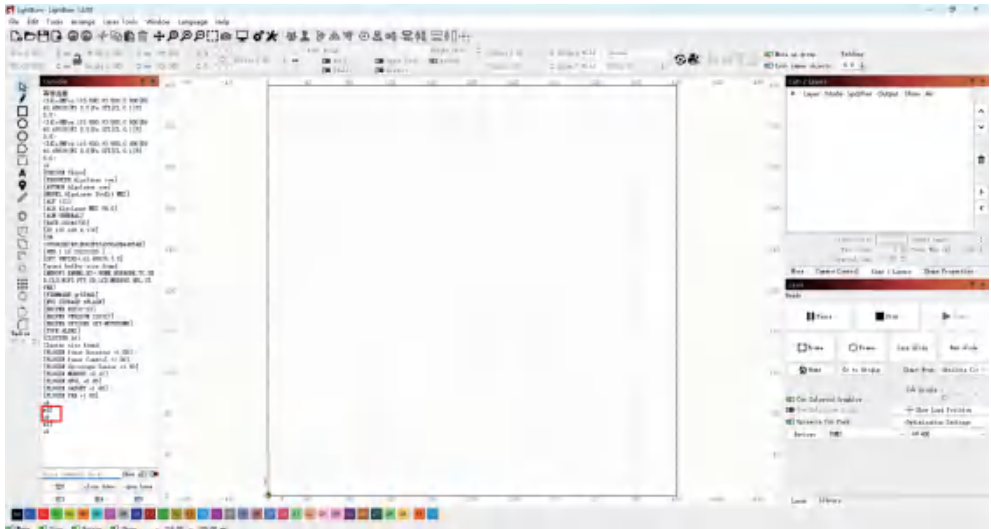

- Send "M13" to the console field to turn off the lights.

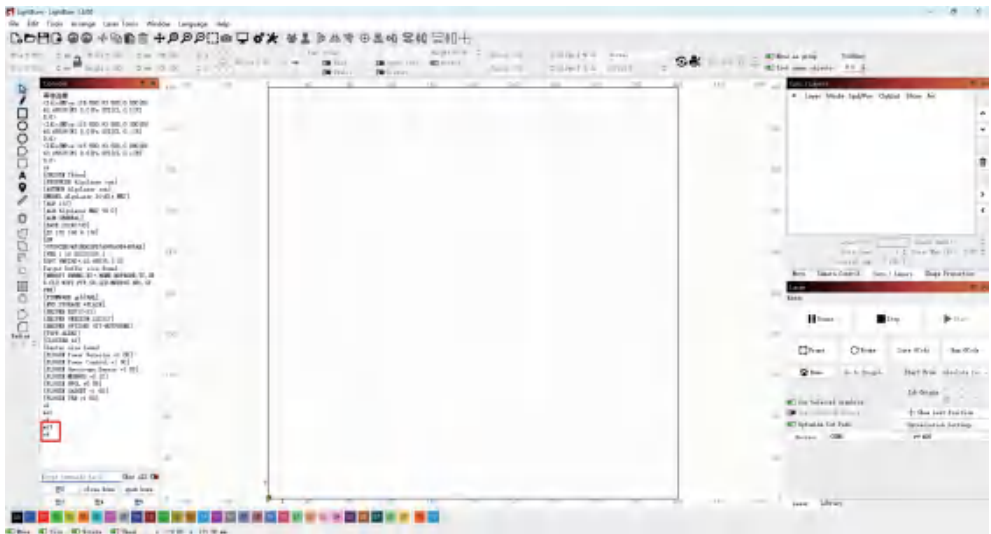

- Send "M14" to the console field to turn on the fan.

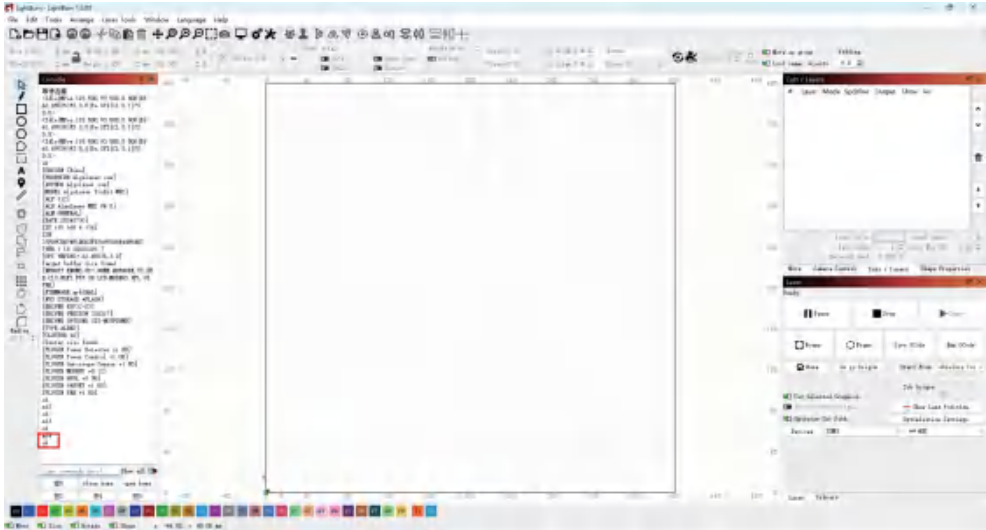

- Send "M15" to the console field to turn off the fan.

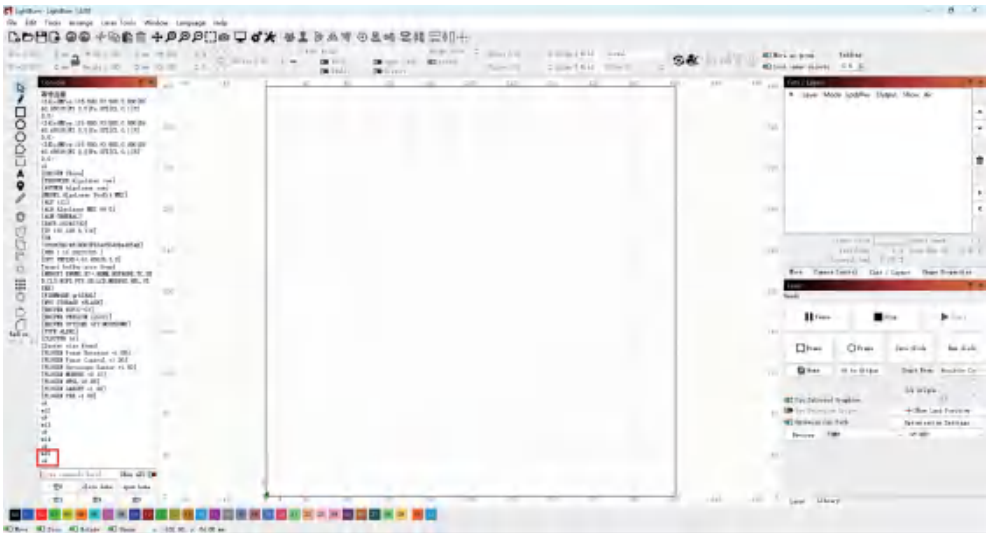

### 3.4 Use LightBurn to Control Camera

- In the Laser Tools menu, select Camera Lens Calibration. Choose HDR Camera in the list, select Standard Lens, click Next.

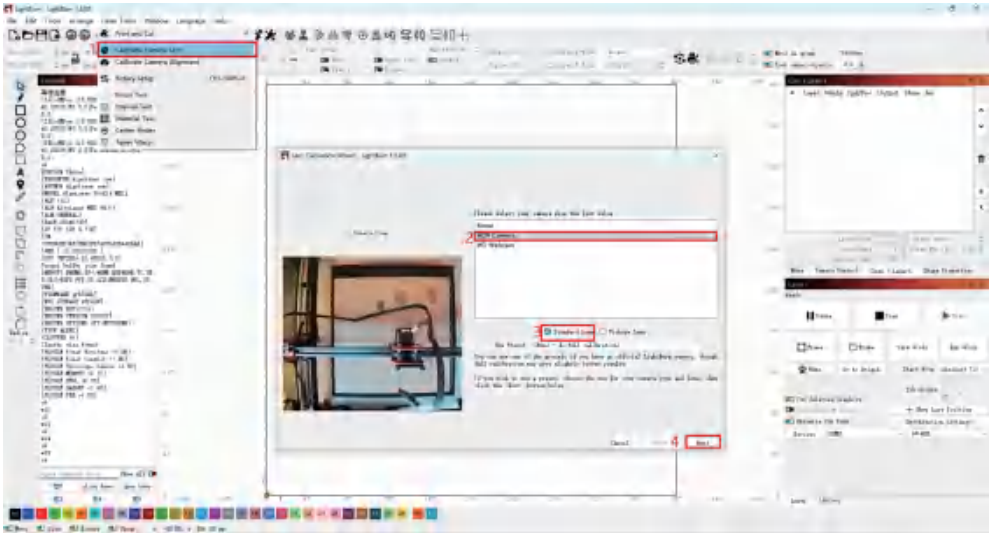

- In the Lens Calibration Wizard window, close honeycomb check enabled. Click Capture button to capture the image, click Next.

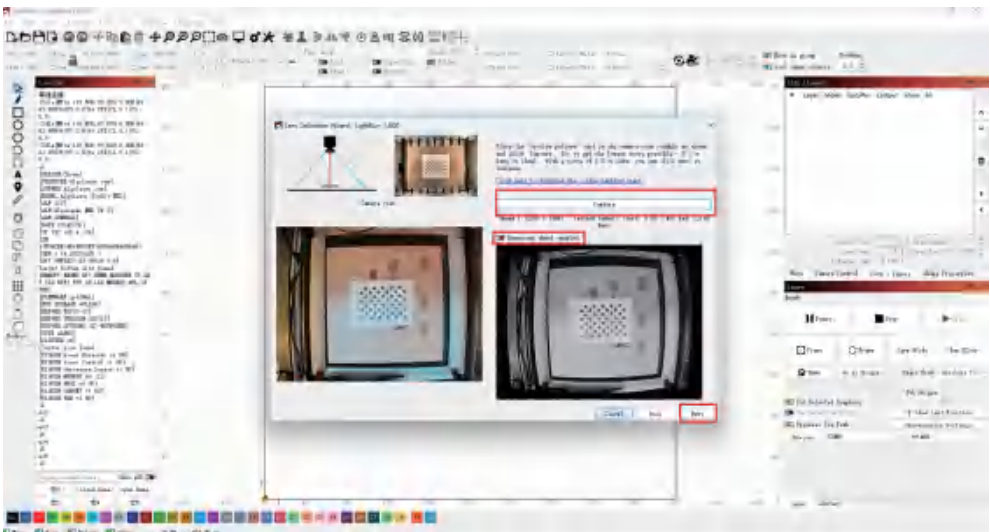



- With a score of 0.3-1.0, you can click Next to continue. Click Next and repeat the steps above for 9 times to capture 9 images of different position. Click Next to enter the next page. In the "Tools" menu, choose "Calibrate Camera Alignment" to start the alignment wizard. After verifying that you see an image from the camera, click "Next" to enter the alignment wizard.

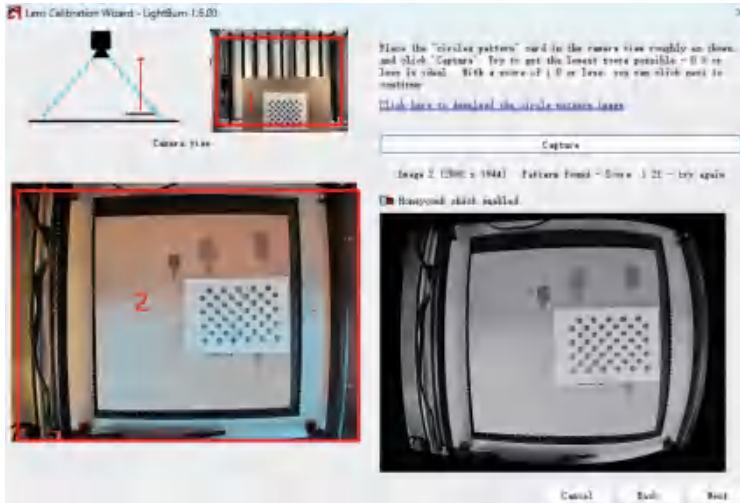

- Enter appropriate settings according to your machine, laser module and material. The engraving pattern preview is on the "Sample Image" part in the diagram below. The pattern is used to align the camera view. Click Frame to ensure the position. Click Start to engrave.

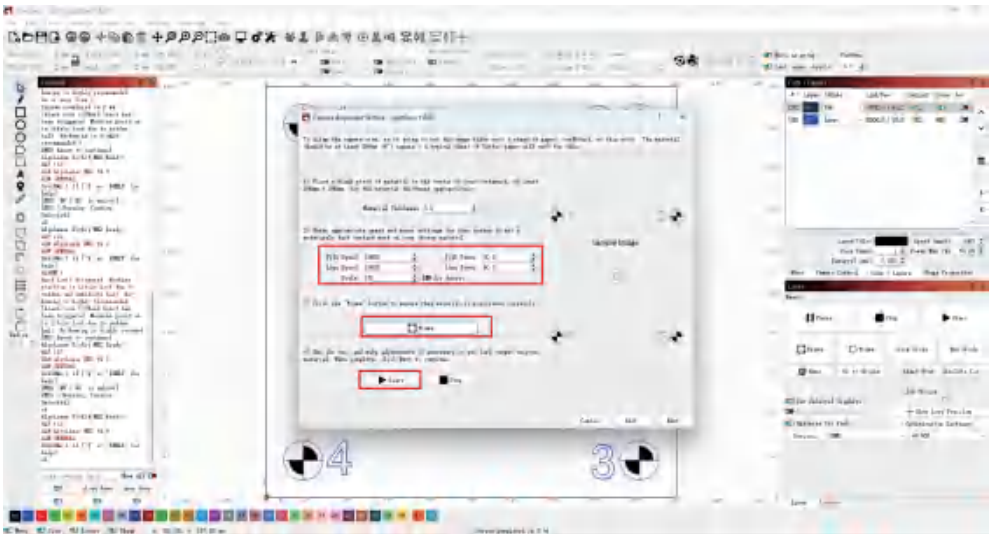

- Click “Capture Image” button to get the image on the right side of the diagram below. Click Next.



- Camera alignment guidance->double-click '+' marks in the order they are numbered (1, 2, 3, 4). Click Next to continue.

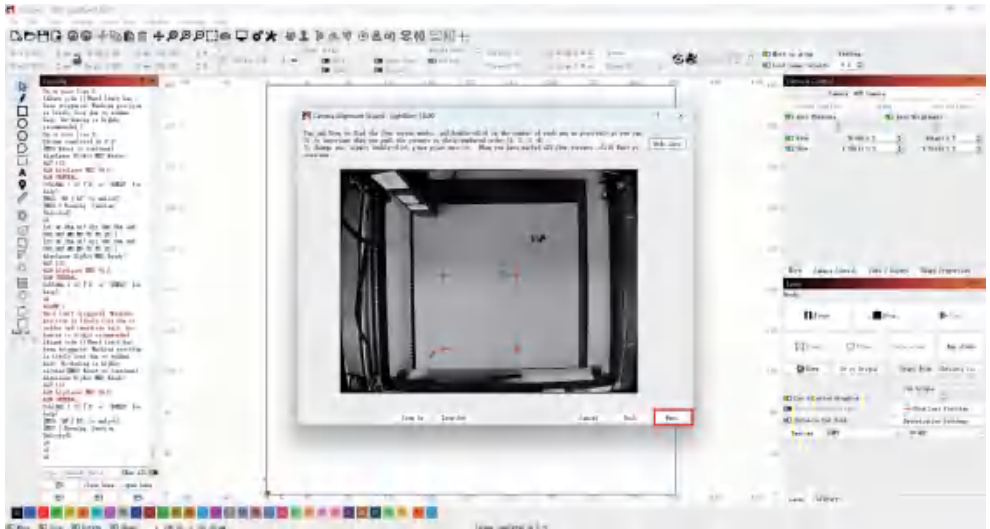

- Camera alignment guidance->Click "Finish" button to end.

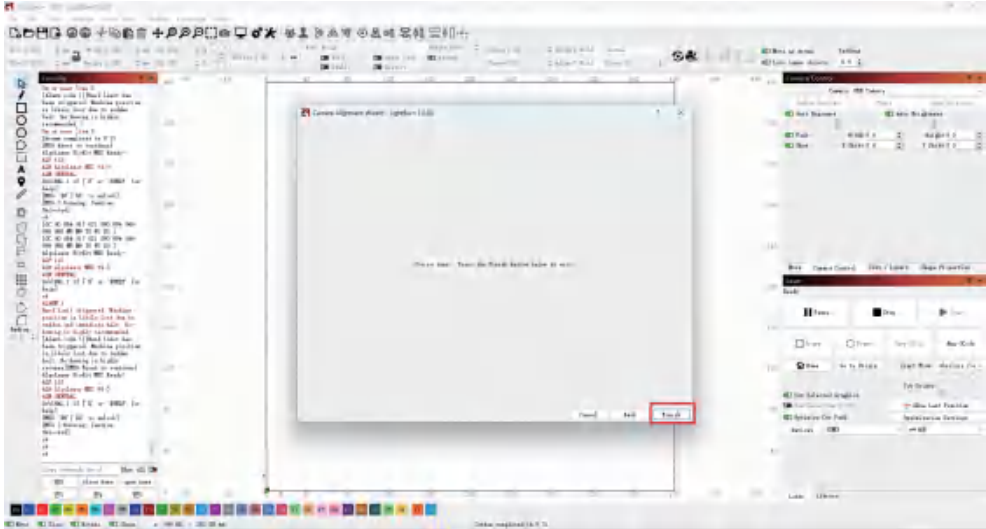

- In the Window menu, select Camera Control.

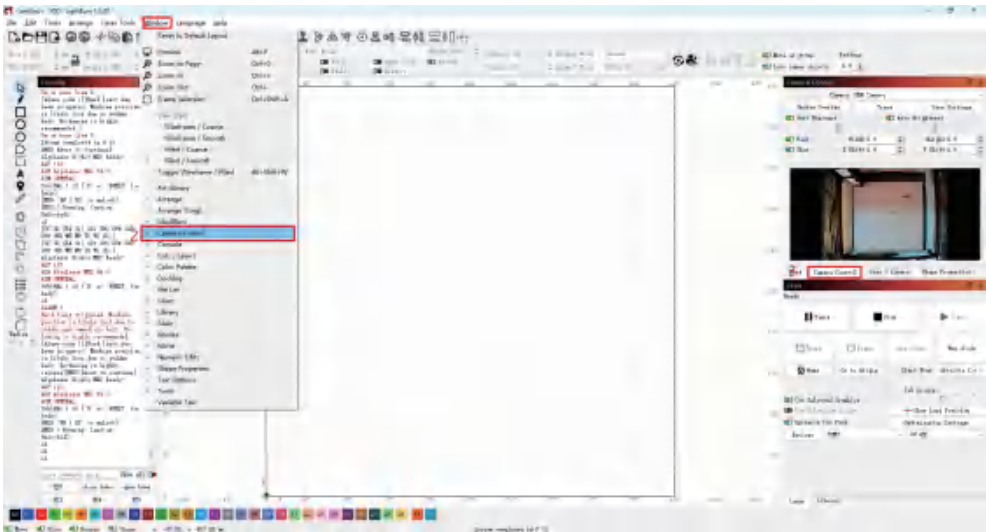

- Select an appropriate camera, update the camera and get an image.

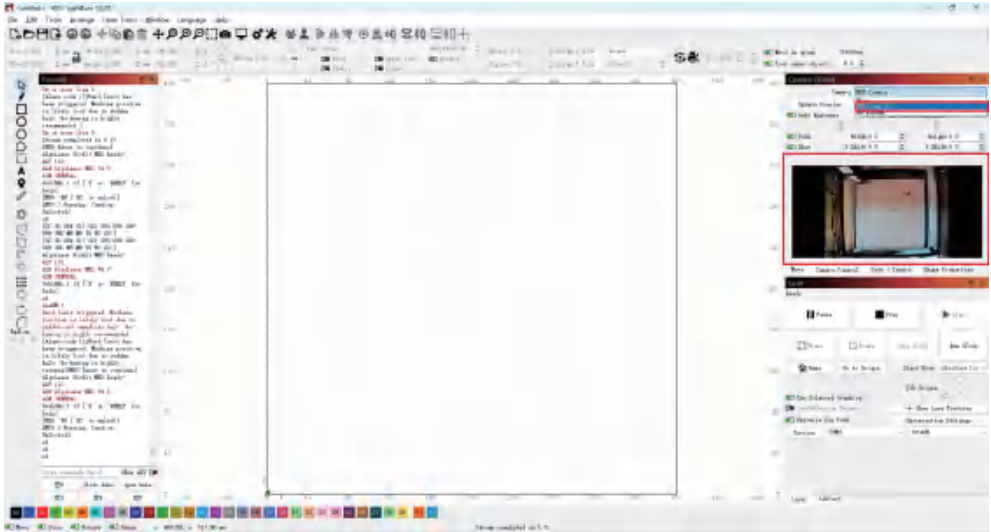

- Click the button on the diagram below, if the laser module is right on the position you clicked, it means the camera is successfully aligned.

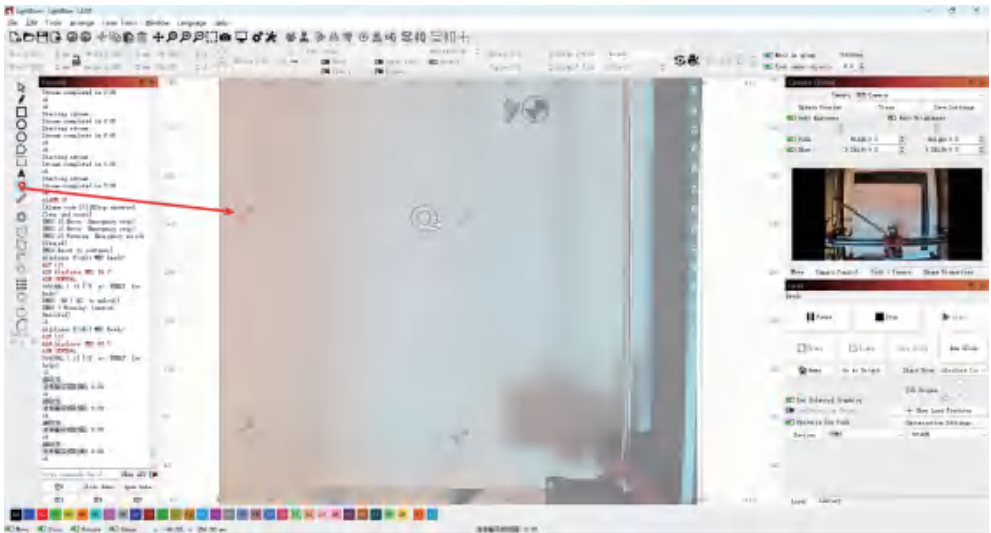

- After the camera alignment, the machine can be used normally.

### 3.5 Use LaserGRBL to Operate

- Use the right COM. Make sure the machine is not connected with another software. Click the connect icon( as shown in the diagram below) to connect.

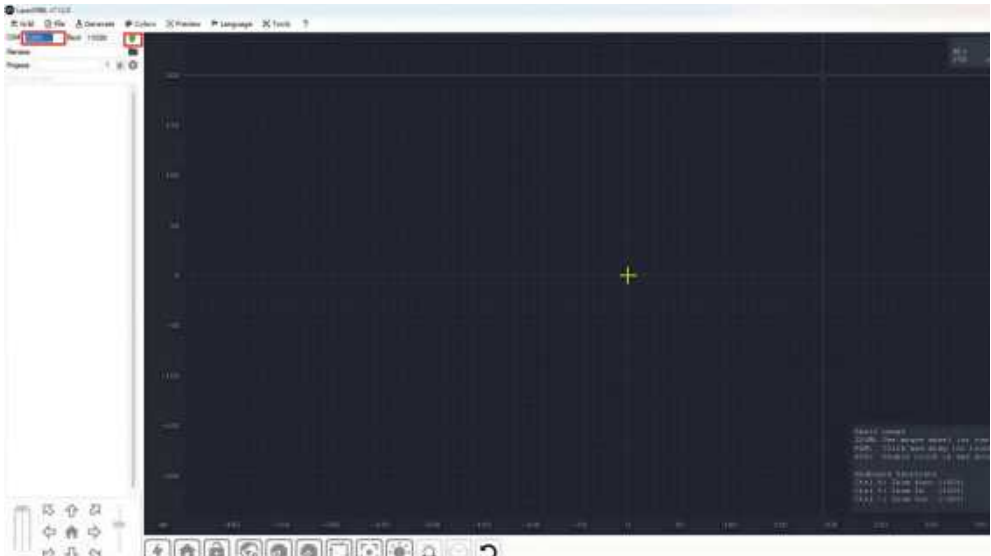

- After connection, send "M12" to the field to turn on the lights.

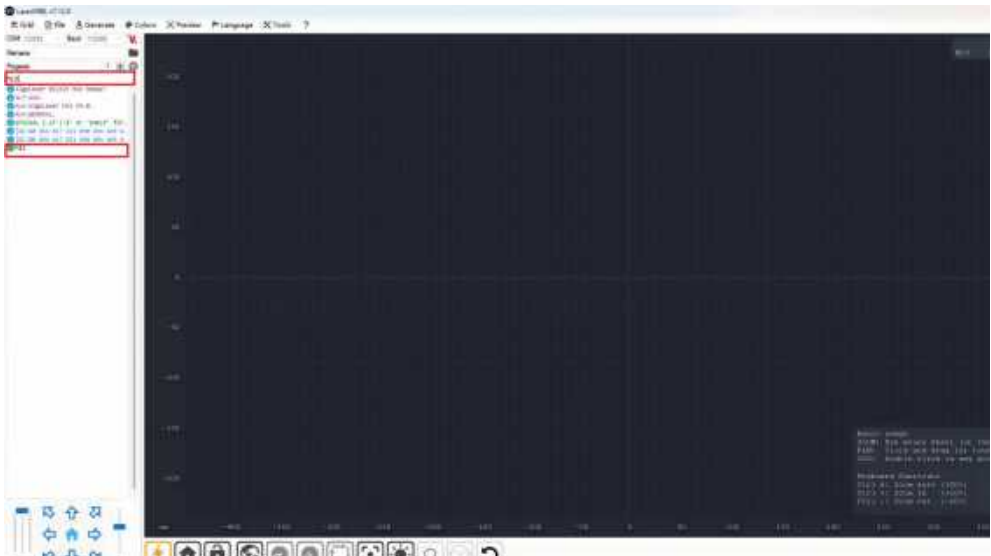

- Send "M13" to the field to turn off the lights.

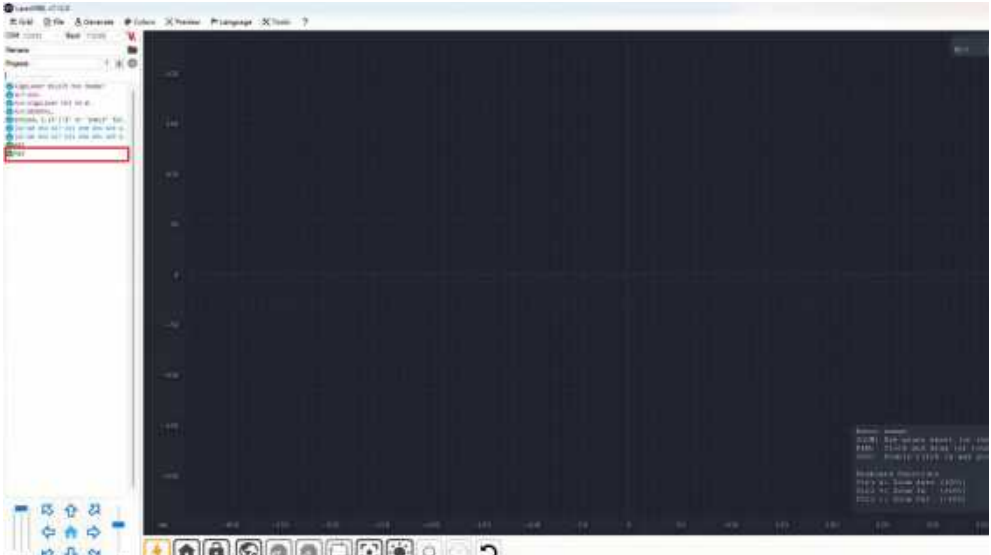

- Send "M14" to the field to turn on the fan.



- Send "M15" to the field to turn off the fan.

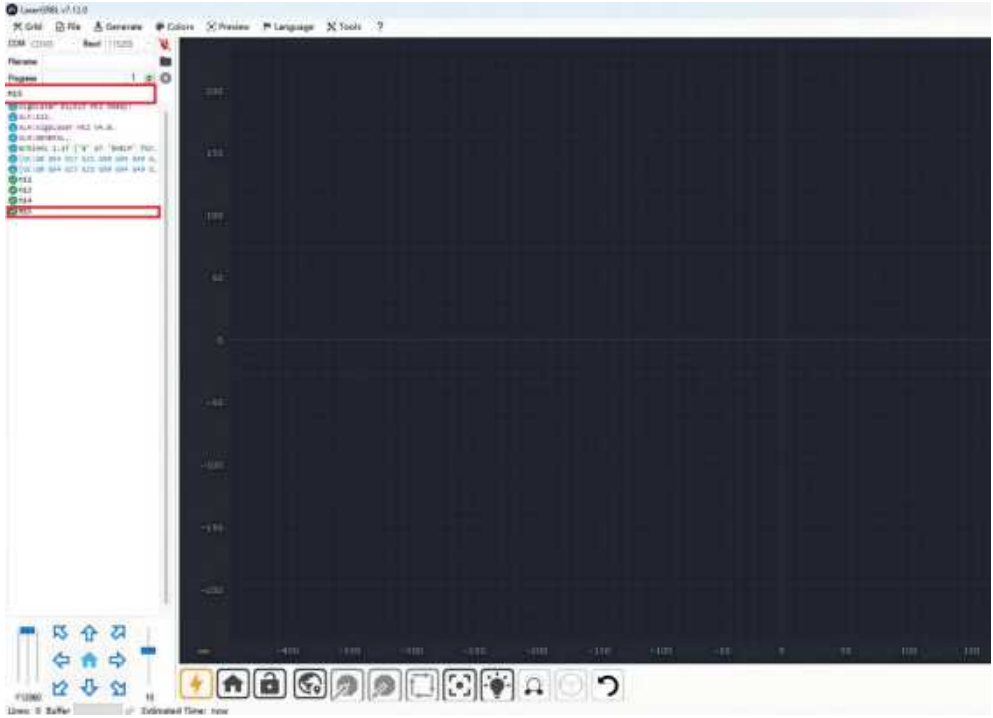

## FAQ

### **No response from the machine when being powered on.**

- No power supply: Please check the socket and switch as well as the machine power socket to ensure that they have been correctly plugged with normal power supply.

### **It cannot be connected to computer.**

- USB cable not connected: Please check the USB data cable interface on the machine and computer to ensure it's correctly plugged in. The USB interface on the front panel of some desktop computers is invalid, it's better to connect to the interface on the back.
- Driver not properly installed: Install the driver according to the instructions. After the installation is done, the computer will recognize the device as a serial port, which means the hardware connection is OK.
- Other special problems: Pull out the USB data cable and power cable, keep the machine power off for 5 seconds and then try the connection once again.

### **No response from the phone APP when being connected to the machine.**

- Wrong Bluetooth connection: Make sure it's connected to the Bluetooth released by the machine. Please read "App Connection" in the User Manual for details.
- Incompatibility: In the case of abnormal connection due to incompatibility of newly-released phone or upgraded system, please contact our customer service with the screenshot of phone configuration so as to get technical support as soon as possible.

### **Shallow engraving effect or no traces.**

- Inaccurate focus: Refer to the "Focus Adjustment" in the User Manual to make the correct focus.
- Engraving speed: Too fast speed is due to short burning time. Please read the "Engraving Parameters" in the Manual to readjust the parameters.
- Photo color is too light: The photo added should be clear. If the line is too thin or the color is too light, the engraving effect will be directly influenced.
- Position of object to be engraved: If the object is placed obliquely, the focal length of laser is fixed, so the object should be placed horizontally in parallel to the machine; otherwise, the inaccurate focal length will result in bad engraving effect.

### **Offline engraving unexpectedly stops**

- The photo is not completely downloaded when being connected to computer, please download the photo once again.



# Certificate



**Certificate of Conformity**  
Certificate Number: 16.2020.02098C

**Applicant:** Shenzhen Algo Technologies Co., Ltd.  
8th Floor, Building B3, Juyin Technology Industrial Park, GaoDi Road, Longgang District, Shenzhen 518110, China

**Manufacturer:** Shenzhen Algo Technologies Co., Ltd.  
8th Floor, Building B3, Juyin Technology Industrial Park, GaoDi Road, Longgang District, Shenzhen 518110, China

**Product:** Smart IRU

**Model No.:** ALH01 A  
ALH01 B, ALH01 C, ALH01 D, ALH01 E, ALH01 F, ALH01 G, ALH01 H, ALH01 I, ALH01 J, ALH01 K, ALH01 L, ALH01 M, ALH01 N, ALH01 O, ALH01 P, ALH01 Q, ALH01 R, ALH01 S, ALH01 T, ALH01 U, ALH01 V, ALH01 W, ALH01 X, ALH01 Y, ALH01 Z

**Test Standard:** EM 15322-2:2019-01:2021  
EM IEC 61326-2-2:2019-01:2021 EM 61326-1-2:2013-01:2019-04:2021  
EM IEC 61326-1-1:2013  
EM IEC 61326-2-1:2013  
EM IEC 61326-2-2:2013  
EM IEC 61326-2-3:2013  
EM IEC 61326-2-4:2013  
EM IEC 61326-2-5:2013  
EM IEC 61326-2-6:2013  
EM IEC 61326-2-7:2013  
EM IEC 61326-2-8:2013  
EM IEC 61326-2-9:2013  
EM IEC 61326-2-10:2013  
EM IEC 61326-2-11:2013  
EM IEC 61326-2-12:2013  
EM IEC 61326-2-13:2013  
EM IEC 61326-2-14:2013  
EM IEC 61326-2-15:2013  
EM IEC 61326-2-16:2013  
EM IEC 61326-2-17:2013  
EM IEC 61326-2-18:2013  
EM IEC 61326-2-19:2013  
EM IEC 61326-2-20:2013  
EM IEC 61326-2-21:2013  
EM IEC 61326-2-22:2013  
EM IEC 61326-2-23:2013  
EM IEC 61326-2-24:2013  
EM IEC 61326-2-25:2013  
EM IEC 61326-2-26:2013  
EM IEC 61326-2-27:2013  
EM IEC 61326-2-28:2013  
EM IEC 61326-2-29:2013  
EM IEC 61326-2-30:2013  
EM IEC 61326-2-31:2013  
EM IEC 61326-2-32:2013  
EM IEC 61326-2-33:2013  
EM IEC 61326-2-34:2013  
EM IEC 61326-2-35:2013  
EM IEC 61326-2-36:2013  
EM IEC 61326-2-37:2013  
EM IEC 61326-2-38:2013  
EM IEC 61326-2-39:2013  
EM IEC 61326-2-40:2013  
EM IEC 61326-2-41:2013  
EM IEC 61326-2-42:2013  
EM IEC 61326-2-43:2013  
EM IEC 61326-2-44:2013  
EM IEC 61326-2-45:2013  
EM IEC 61326-2-46:2013  
EM IEC 61326-2-47:2013  
EM IEC 61326-2-48:2013  
EM IEC 61326-2-49:2013  
EM IEC 61326-2-50:2013  
EM IEC 61326-2-51:2013  
EM IEC 61326-2-52:2013  
EM IEC 61326-2-53:2013  
EM IEC 61326-2-54:2013  
EM IEC 61326-2-55:2013  
EM IEC 61326-2-56:2013  
EM IEC 61326-2-57:2013  
EM IEC 61326-2-58:2013  
EM IEC 61326-2-59:2013  
EM IEC 61326-2-60:2013  
EM IEC 61326-2-61:2013  
EM IEC 61326-2-62:2013  
EM IEC 61326-2-63:2013  
EM IEC 61326-2-64:2013  
EM IEC 61326-2-65:2013  
EM IEC 61326-2-66:2013  
EM IEC 61326-2-67:2013  
EM IEC 61326-2-68:2013  
EM IEC 61326-2-69:2013  
EM IEC 61326-2-70:2013  
EM IEC 61326-2-71:2013  
EM IEC 61326-2-72:2013  
EM IEC 61326-2-73:2013  
EM IEC 61326-2-74:2013  
EM IEC 61326-2-75:2013  
EM IEC 61326-2-76:2013  
EM IEC 61326-2-77:2013  
EM IEC 61326-2-78:2013  
EM IEC 61326-2-79:2013  
EM IEC 61326-2-80:2013  
EM IEC 61326-2-81:2013  
EM IEC 61326-2-82:2013  
EM IEC 61326-2-83:2013  
EM IEC 61326-2-84:2013  
EM IEC 61326-2-85:2013  
EM IEC 61326-2-86:2013  
EM IEC 61326-2-87:2013  
EM IEC 61326-2-88:2013  
EM IEC 61326-2-89:2013  
EM IEC 61326-2-90:2013  
EM IEC 61326-2-91:2013  
EM IEC 61326-2-92:2013  
EM IEC 61326-2-93:2013  
EM IEC 61326-2-94:2013  
EM IEC 61326-2-95:2013  
EM IEC 61326-2-96:2013  
EM IEC 61326-2-97:2013  
EM IEC 61326-2-98:2013  
EM IEC 61326-2-99:2013  
EM IEC 61326-2-100:2013

The EUT marked model has been tested by us with the intent and objective to verify its compliance with the relevant EMC directives 2014/53/EU, it is possible to fulfil CE marking in accordance with conditions with the EMC Directive in a single state of construction with the test report number: 16.2020.02098C

**CE**



The granting of a certificate is based on a single assessment of the information provided by the Applicant. The Applicant is responsible for the accuracy of the information provided and for ensuring that the information provided is correct and complete. It is not recommended to copy or reuse the information provided without the written consent of the Applicant.

Shenzhen Algo Technologies Co., Ltd.  
8th Floor, Building B3, Juyin Technology Industrial Park, GaoDi Road, Longgang District, Shenzhen 518110, China  
Tel: +86 755 8518 8888  
www.algo.com



**Supplier's Declaration of Conformity**  
Certificate Number: 16.2020.02098C

**Applicant:** Shenzhen Algo Technologies Co., Ltd.  
8th Floor, Building B3, Juyin Technology Industrial Park, GaoDi Road, Longgang District, Shenzhen 518110, China

**Manufacturer:** Shenzhen Algo Technologies Co., Ltd.  
8th Floor, Building B3, Juyin Technology Industrial Park, GaoDi Road, Longgang District, Shenzhen 518110, China

**Product:** Smart IRU

**Model No.:** ALH01 A  
ALH01 B, ALH01 C, ALH01 D, ALH01 E, ALH01 F, ALH01 G, ALH01 H, ALH01 I, ALH01 J, ALH01 K, ALH01 L, ALH01 M, ALH01 N, ALH01 O, ALH01 P, ALH01 Q, ALH01 R, ALH01 S, ALH01 T, ALH01 U, ALH01 V, ALH01 W, ALH01 X, ALH01 Y, ALH01 Z

**Test Standard:** FCC 47 CFR Part 15  
AMM 15.4.2014

The Applicant is a user of the FCC test results and is aware of the conditions of use. The Applicant has reported that the FCC test results are correct and that the information provided is accurate and complete. It is not recommended to copy or reuse the information provided without the written consent of the Applicant.

**FCC**



The granting of a certificate is based on a single assessment of the information provided by the Applicant. The Applicant is responsible for the accuracy of the information provided and for ensuring that the information provided is correct and complete. It is not recommended to copy or reuse the information provided without the written consent of the Applicant.

Shenzhen Algo Technologies Co., Ltd.  
8th Floor, Building B3, Juyin Technology Industrial Park, GaoDi Road, Longgang District, Shenzhen 518110, China  
Tel: +86 755 8518 8888  
www.algo.com



**Certificate of Conformity**  
Certificate Number: 16.2020.02098C

**Applicant:** Shenzhen Algo Technologies Co., Ltd.  
8th Floor, Building B3, Juyin Technology Industrial Park, GaoDi Road, Longgang District, Shenzhen 518110, China

**Manufacturer:** Shenzhen Algo Technologies Co., Ltd.  
8th Floor, Building B3, Juyin Technology Industrial Park, GaoDi Road, Longgang District, Shenzhen 518110, China

**Product:** Smart IRU

**Model No.:** ALH01 A  
ALH01 B, ALH01 C, ALH01 D, ALH01 E, ALH01 F, ALH01 G, ALH01 H, ALH01 I, ALH01 J, ALH01 K, ALH01 L, ALH01 M, ALH01 N, ALH01 O, ALH01 P, ALH01 Q, ALH01 R, ALH01 S, ALH01 T, ALH01 U, ALH01 V, ALH01 W, ALH01 X, ALH01 Y, ALH01 Z

**Test Standard:** IEC 62321-1:2014  
IEC 62321-2:2014  
IEC 62321-3:2014  
IEC 62321-4:2014  
IEC 62321-5:2014  
IEC 62321-6:2014  
IEC 62321-7:2014  
IEC 62321-8:2014  
IEC 62321-9:2014  
IEC 62321-10:2014  
IEC 62321-11:2014  
IEC 62321-12:2014  
IEC 62321-13:2014  
IEC 62321-14:2014  
IEC 62321-15:2014  
IEC 62321-16:2014  
IEC 62321-17:2014  
IEC 62321-18:2014  
IEC 62321-19:2014  
IEC 62321-20:2014  
IEC 62321-21:2014  
IEC 62321-22:2014  
IEC 62321-23:2014  
IEC 62321-24:2014  
IEC 62321-25:2014  
IEC 62321-26:2014  
IEC 62321-27:2014  
IEC 62321-28:2014  
IEC 62321-29:2014  
IEC 62321-30:2014  
IEC 62321-31:2014  
IEC 62321-32:2014  
IEC 62321-33:2014  
IEC 62321-34:2014  
IEC 62321-35:2014  
IEC 62321-36:2014  
IEC 62321-37:2014  
IEC 62321-38:2014  
IEC 62321-39:2014  
IEC 62321-40:2014  
IEC 62321-41:2014  
IEC 62321-42:2014  
IEC 62321-43:2014  
IEC 62321-44:2014  
IEC 62321-45:2014  
IEC 62321-46:2014  
IEC 62321-47:2014  
IEC 62321-48:2014  
IEC 62321-49:2014  
IEC 62321-50:2014  
IEC 62321-51:2014  
IEC 62321-52:2014  
IEC 62321-53:2014  
IEC 62321-54:2014  
IEC 62321-55:2014  
IEC 62321-56:2014  
IEC 62321-57:2014  
IEC 62321-58:2014  
IEC 62321-59:2014  
IEC 62321-60:2014  
IEC 62321-61:2014  
IEC 62321-62:2014  
IEC 62321-63:2014  
IEC 62321-64:2014  
IEC 62321-65:2014  
IEC 62321-66:2014  
IEC 62321-67:2014  
IEC 62321-68:2014  
IEC 62321-69:2014  
IEC 62321-70:2014  
IEC 62321-71:2014  
IEC 62321-72:2014  
IEC 62321-73:2014  
IEC 62321-74:2014  
IEC 62321-75:2014  
IEC 62321-76:2014  
IEC 62321-77:2014  
IEC 62321-78:2014  
IEC 62321-79:2014  
IEC 62321-80:2014  
IEC 62321-81:2014  
IEC 62321-82:2014  
IEC 62321-83:2014  
IEC 62321-84:2014  
IEC 62321-85:2014  
IEC 62321-86:2014  
IEC 62321-87:2014  
IEC 62321-88:2014  
IEC 62321-89:2014  
IEC 62321-90:2014  
IEC 62321-91:2014  
IEC 62321-92:2014  
IEC 62321-93:2014  
IEC 62321-94:2014  
IEC 62321-95:2014  
IEC 62321-96:2014  
IEC 62321-97:2014  
IEC 62321-98:2014  
IEC 62321-99:2014  
IEC 62321-100:2014

The EUT marked model has been tested by us with the intent and objective to verify its compliance with the relevant RoHS directives 2011/65/EU, it is possible to fulfil RoHS marking in accordance with conditions with the RoHS Directive in a single state of construction with the test report number: 16.2020.02098C

**RoHS**



The granting of a certificate is based on a single assessment of the information provided by the Applicant. The Applicant is responsible for the accuracy of the information provided and for ensuring that the information provided is correct and complete. It is not recommended to copy or reuse the information provided without the written consent of the Applicant.

Shenzhen Algo Technologies Co., Ltd.  
8th Floor, Building B3, Juyin Technology Industrial Park, GaoDi Road, Longgang District, Shenzhen 518110, China  
Tel: +86 755 8518 8888  
www.algo.com



## FCC Compliance Statements

This device complies with Part 15 of the FCC Rules. Operation is subject to the following two conditions: (1) this device may not cause harmful interference, and (2) this device must accept any interference received, including interference that may cause undesired operation.

Caution: Changes or modifications not expressly approved by the party responsible for compliance could void the user's authority to operate the equipment.

Note: This equipment has been tested and found to comply with the limits for a Class B digital device, pursuant to Part 15 of the FCC Rules. These limits are designed to provide reasonable protection against harmful interference in a residential installation. This equipment generates, uses and can radiate radio frequency energy and, if not installed and used in accordance with the instructions, may cause harmful interference to radio communications. However, there is no guarantee that interference will not occur in a particular installation.

If this equipment does cause harmful interference to radio or television reception, which can be determined by turning the equipment off and on, the user is encouraged to try to correct the interference by one or more of the following measures:

- Reorient or relocate the receiving antenna.
- Increase the separation between the equipment and receiver.
- Connect the equipment into an outlet on a circuit different from that to which the receiver is connected.
- Consult the dealer or an experienced radio/TV technician for help.

## ISED Compliance Statements

This device contains licence-exempt transmitter(s)/receiver(s) that comply with Innovation, Science and Economic Development Canada's licence-exempt RSS(s). Operation is subject to the following two conditions:

- (1) This device may not cause interference.
- (2) This device must accept any interference, including interference that may cause undesired operation of the device.

This equipment complies with IC RSS-102 radiation exposure limits set forth for an uncontrolled environment.

L'émetteur/récepteur exempt de licence contenu dans le présent appareil est conforme aux CNR d'Innovation, Sciences et Développement économique Canada applicables aux appareils radio exempts de licence. L'exploitation est autorisée aux deux conditions suivantes :

- (1) L'appareil ne doit pas produire de brouillage;
- (2) L'appareil doit accepter tout brouillage radioélectrique subi, même si le brouillage est susceptible d'en compromettre le fonctionnement.

Cet équipement est conforme aux limites d'exposition aux radiations IC CNR-102 établies pour un environnement non contrôlé.

## RF Exposure Compliance

This equipment complies with FCC/IC RSS-102 radiation exposure limits set forth for an uncontrolled environment. This equipment should be installed and operated with minimum distance 20cm between the radiator and your body. This transmitter must not be co-located or operating in conjunction with any other antenna or transmitter.

Cet équipement est conforme aux limites d'exposition aux radiations IC CNR-102 établies pour un environnement non contrôlé. Cet équipement doit être installé et utilisé avec une distance minimale de 20cm entre le radiateur et votre corps. Cet émetteur ne doit pas être colocalisé ou fonctionner en conjonction avec une autre antenne ou un autre émetteur.





---

## Follow us! #AlgoLaser

 AlgoLaser Official

 AlgoLaser\_Official

 Algolaserofficial

 algo.laser

 AlgoLaser Official User Group

 AlgoLaser Official

---



**MADE IN CHINA**



[www.algolaser.com/support/](http://www.algolaser.com/support/)

# 此页不印刷



蓝色色号: PANTONE 2955 C



橙色色号: PANTONE 16-1358TP (Orange Tiger)

版本 /REV.		修订内容 /Revision Note				日期 /Date	确认人 /Check By
比例 /SCALE	1:1	单位 /UNIT	毫米 /mm	深圳奥菲诺科技有限公司			
版本 /REV.	A1						
核准 /APR.		图号 /Drawing NO.	ALSEC2.0-E-01	材料 /Material	封面 200g铜版纸 内页 80g铜版纸	尺寸	160*215mm
审核 /CHK.		品名 /P/N.	防火箱2.0 说明书	装订方式 /ST.	骑马钉	页次 /Page.	20
绘图 /DRAWN.	曾玲玲	机型 /Model.	ALSEC 2.0	物料编码: /Part NO.		日期 /Date.	2024.09.11